



Reyrolle 7SR5 Platform Protecting Grids With Confidence

Reyrolle 7SR5 Catalog · Edition 7.0

SIEMENS

Overview of Documentation

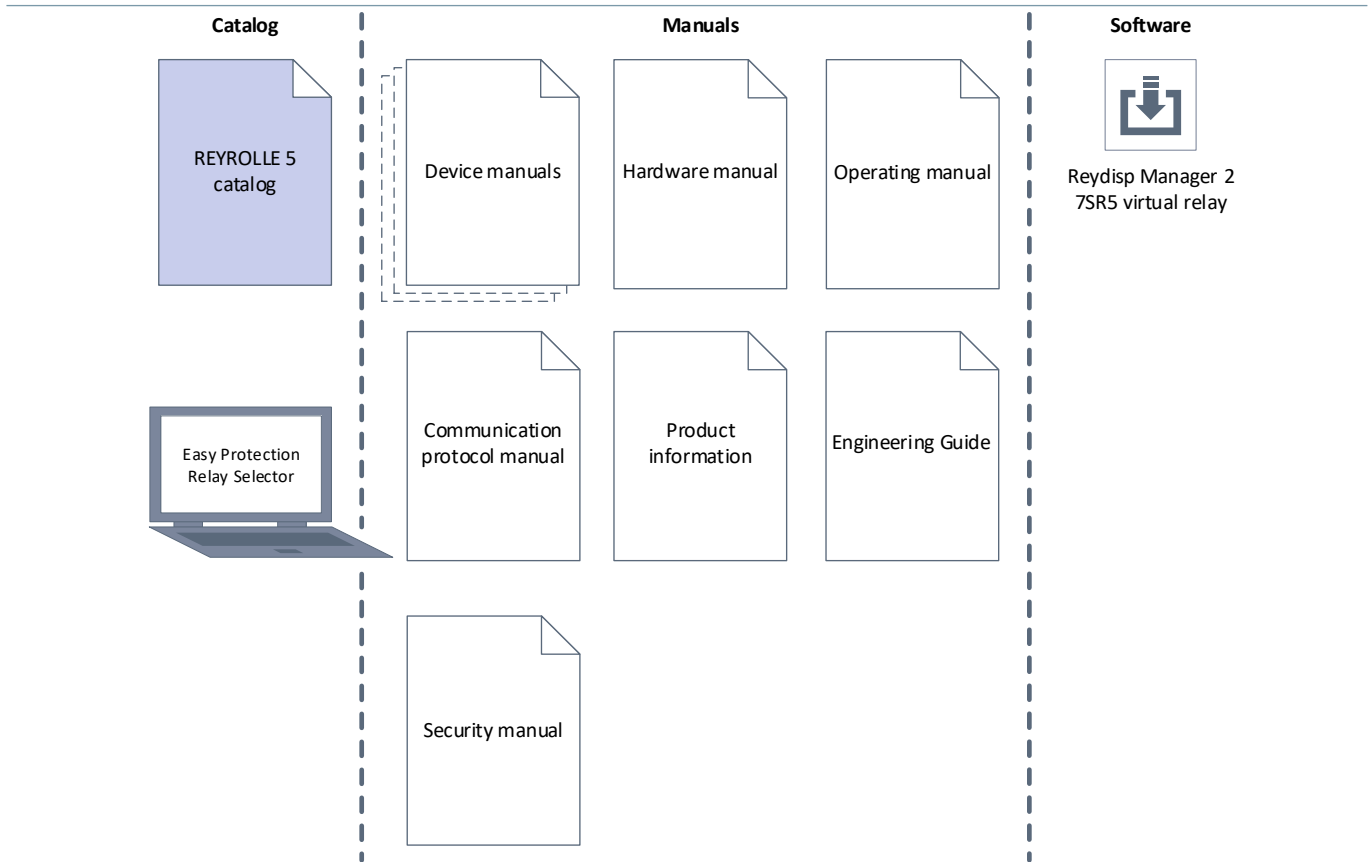

Device manuals

Each device manual describes the functions and applications of a specific Reyrolle 7SR5 device. The printed manual has the same informational structure.

Hardware manual

The hardware manual describes the hardware building blocks and device combinations of the Reyrolle 7SR5 device family.

Operating manual

The operating manual describes the basic principles and procedures for operating and installing the devices of the Reyrolle 7SR5 range.

Communication protocol manual

The communication protocol manual contains a description of the protocols for communication within the Reyrolle 7SR5 device family and to higher-level network control centers.

Security manual

The security manual describes the security features of the Reyrolle 7SR5 devices and Reydisp Manager 2.

Product information

The product information includes general information about device installation, technical data, limiting

values for input and output modules, and conditions when preparing for operation. This document is provided with each Reyrolle 7SR5 device.

Engineering Guide

The engineering guide describes the essential steps when engineering with Reydisp Manager 2. In addition, the engineering guide shows you how to load a planned configuration to a Reyrolle 7SR5 device and update the functionality of the Reyrolle 7SR5 device.

Virtual Relay

The virtual relay allows a user to view, control and manipulate a virtual Reyrolle 7SR5 device. The virtual relay is a tool that can facilitate training and understanding of the controls and functions on a Reyrolle 7SR5 device.

Reyrolle 7SR5 catalog

The Reyrolle 7SR5 catalog describes the system features and the devices of Reyrolle 7SR5.

Easy Protection Relay Selector for Reyrolle and SIPROTEC

This tool gives a quick guidance to find a protection relay of SIPROTEC 5, SIPROTEC 4, SIPROTEC Compact, and Reyrolle which would fit your needs.

Reyrolle 7SR5 Platform Catalog Protection, Control, Automation, Monitoring, and Power Quality - Basic

Reyrolle 5 - Catalog Edition 7.0

Introduction	1
Devices and Application	2
Device Types	2.1
Relay Selection Guide	2.2
Application Examples	2.3
Overcurrent Protection	2.4
Transformer Differential Protection	2.5
Motor Protection	2.6
System	3
Protection	3.1
Monitoring	3.2
Data Storage	3.3
Communication	3.4
Hardware Construction	3.5
Technical Documentation	4
Connection Diagrams	4.1
Dimension drawings	4.2
Technical data	4.3
Ordering Information	4.4

Introduction

Reyrolle – Solutions for Distribution Grids

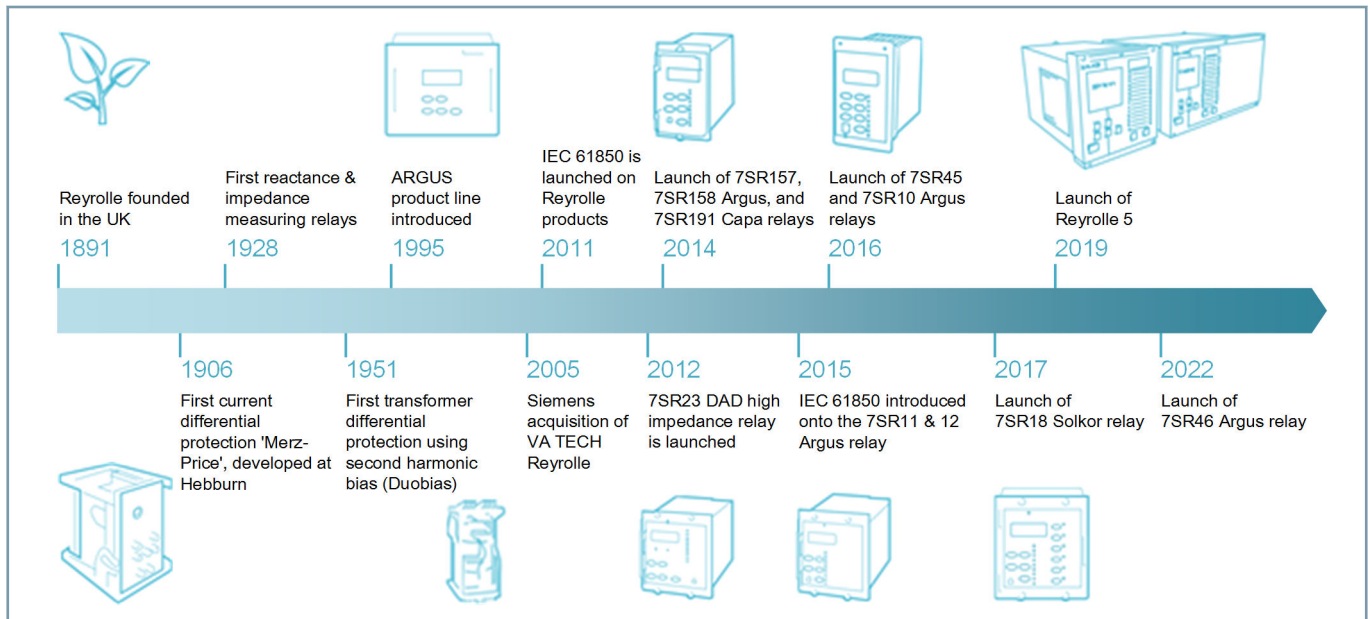

[dsw_reyrolle history, 4, en_US]

Reyrolle digital protection products have established a strong reputation over many years of installed service experience with a large variety of users.

The new Reyrolle 7SR5 devices provide comprehensive functionality and can be implemented in a wide range of applications – typically subtransmission networks, distribution networks, and industrial installations. In these areas the 7SR5 is an integral component and helps provide a secure interconnected power system and is an important part of distributed energy-supply and demand systems.

The 7SR5 is the new generation of 7SR devices providing an updated user interface linking to the latest hardware platform and software implementation. The hardware platform offers a flexible solution relevant to changing power grids and load flows. The 7SR5 builds on the proven performance of the existing 7SR1 and 7SR2 products, the function implementation and user interface are instantly recognizable to users of previous generation products but have also has been updated and enhanced. In-service experience and the need for future proofing has been incorporated by implementing flexible modular hardware architecture and modular software structure.

Many enhancements and additions to the 7SR product construction and functionality have been incorporated into the 7SR5, these include:

- Flexible hardware – minimized ordering options
- Full applications functionality is available in each device
- Large LCD facilitates device setting and display of network status from the front fascia
- 28 LEDs as standard
- Selectable binary input operating thresholds
- IP54 from front
- 3-winding transformer protection
- Additional standard front pushbuttons improve flexibility

- Standard IEC 61850 functionality supports system automation
- Cyber-security functionality
- User selectable languages: English, French, German, Portuguese, Spanish, Turkish

With the Reyrolle 5 you are able to install a product that will be upgradeable. As the power system grows to meet changing consumer requirements then the 7SR5 device will be reconfigurable without the need for replacement devices. The specific fit required for the application will be provided by the 7SR5 both at the time of installation and when future network and automation changes are required.



[re_7SR5Family, 1, en_US]

Figure 1/1 Reyrolle 7SR5 Family

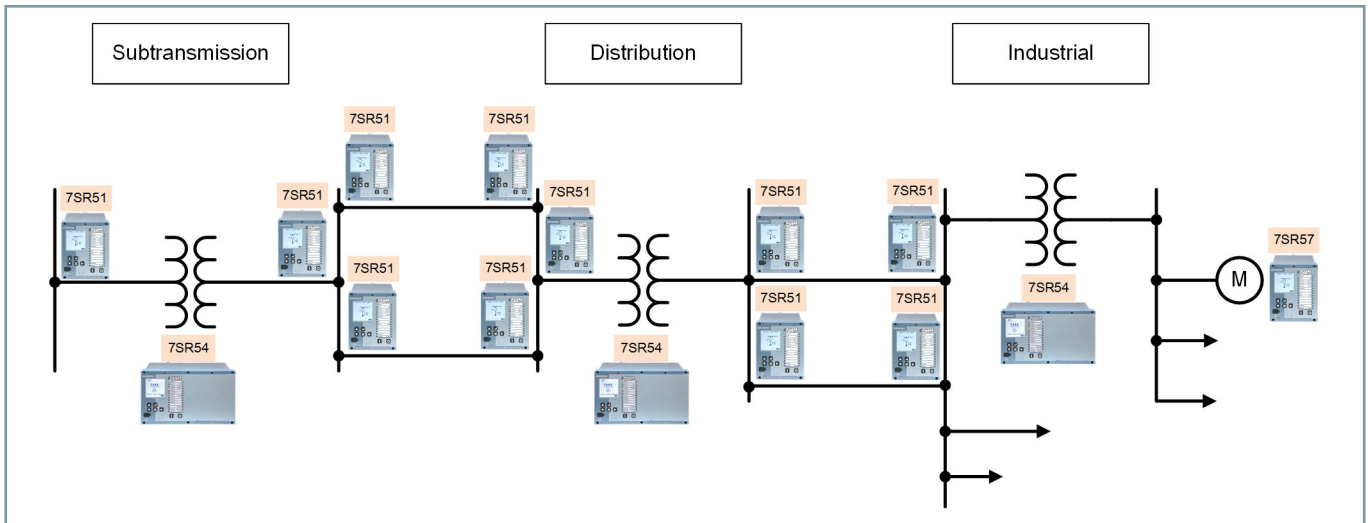

[dw_7SR5_devicetypes, 4, en_US]

Devices and Application

Device Types

Main function	Device
Overcurrent and Feeder Protection	
Overcurrent Protection with control and monitoring	7SR51
Transformer Differential Protection	
Transformer Differential Protection with control and monitoring	7SR54
Motor Protection	
Motor Protection with control and monitoring	7SR57

2.1

ANSI	Functions	7SR5110 Overcurrent	7SR5111 Directional Overcurrent	7SR5121 Directional Overcurrent	7SR5420 2 Winding Transformer	7SR5421 2 Winding Transformer	7SR5430 3 Winding Transformer	7SR5431 3 Winding Transformer	7SR5710 Motor	7SR5711 Motor	7SR572 Motor
14	Locked rotor protection	-	-	-	-	-	-	-	■	■	■
21FL	Fault locator	-	■	■	-	-	-	-	-	-	-
21LB	Load blinder	-	■	■	-	■	-	■	-	-	-
24	Overexcitation protection	-	-	-	-	■	-	■	-	-	-
25	Synchrocheck – synchronization function	-	■	■	-	■	-	■	-	-	-
27	Undervoltage protection – 3-phase	-	■	■	-	■	-	■	-	■	■
27Vx	Undervoltage protection – Vx	-	■	■	-	■	-	■	-	■	■
32	Power protection	-	■	■	-	■	-	■	-	■	■
37	Undercurrent protection – phase	■	■	■	■	■	■	■	■	■	■
37G	Undercurrent earth fault – measured	■	■	■	■	■	■	■	■	■	■
46	Negative sequence overcurrent protection	■	■	■	■	■	■	■	-	-	-
46BC	Broken conductor detection	■	■	■	■	■	■	■	■	■	■
46PR	Phase-rotation reversal	-	-	-	-	-	-	-	■	■	■
46UB	Phase unbalance	-	-	-	-	-	-	-	■	■	■
47	Sequence overvoltage protection	-	■	■	-	■	-	■	-	■	■
48	Starting-time supervision	-	-	-	-	-	-	-	■	■	■
49	Thermal overload protection	■	■	■	■	■	■	■	-	-	-
49M	Motor thermal overload protection	-	-	-	-	-	-	-	■	■	■
49TS	Temperature sensor supervision ¹	■	■	■	■	■	■	■	■	■	■
50	Instantaneous overcurrent – phase	■	■	■	■	■	■	■	■	■	■
50AFD	Arc flash detection ²	■	■	■	■	■	■	■	■	■	■
50BCL	Break capacity limit	-	-	-	-	-	-	-	■	■	■
50BF	Circuit-breaker failure protection – 3-pole	■	■	■	■	■	■	■	■	■	■
50G	Instantaneous earth fault – measured	■	■	■	■	■	■	■	■	■	■
50GHS	High speed earth fault – measured	■	■	■	-	-	-	-	-	-	-
50GI	Intermittent earth fault	■	■	■	-	-	-	-	-	-	-
50GS	Instantaneous sensitive earth fault – measured	■	■	■	-	-	-	-	-	-	-
50HS	High speed overcurrent – phase	■	■	■	-	-	-	-	-	-	-
50N	Instantaneous earth fault – calculated	■	■	■	■	■	■	■	■	■	■
50SOTF	Switch onto fault	■	■	■	-	-	-	-	-	-	-
51	Time-delayed overcurrent – phase	■	■	■	■	■	■	■	■	■	■
51CL	Cold load overcurrent – phase	■	■	■	■	■	■	■	-	-	-
51G	Time delayed earth fault – measured	■	■	■	■	■	■	■	■	■	■
51GS	Time-delayed sensitive earth fault – measured	■	■	■	-	-	-	-	-	-	-
51N	Time-delayed earth fault – calculated	■	■	■	■	■	■	■	■	■	■
51V	Voltage-dependent overcurrent – phase	-	■	■	-	■	-	■	-	-	-
52	Circuit-breaker control	■	■	■	■	■	■	■	■	■	■
55	Power factor	-	■	■	-	■	-	■	-	■	■

¹ An external interface unit is required where optional TSI module not fitted.

² Requires external components

Devices and Application

Relay Selection Guide

2.2

ANSI	Functions	7SR5110 Overcurrent	7SR5111 Directional Overcurrent	7SR5121 Directional Overcurrent	7SR5420 2 Winding Transformer	7SR5421 2 Winding Transformer	7SR5430 3 Winding Transformer	7SR5431 3 Winding Transformer	7SR5710 Motor	7SR5711 Motor	7SR572 Motor
59	Overvoltage protection – 3-phase	-	■	■	-	■	-	■	-	■	■
59N	Neutral voltage displacement	-	■	■	-	■	-	■	-	■	■
59Vx	Overvoltage protection – Vx	-	■	■	-	■	-	■	-	■	■
60CTS-I	CT supervision – current reference	■	■	■	■	■	■	■	■	-	-
60CTS-V	CT supervision – voltage reference	-	■	■	-	-	-	-	-	■	■
60VTS	VT supervision	-	■	■	-	■	-	■	-	■	■
66	Number of starts	-	-	-	-	-	-	-	■	■	■
67	Directional overcurrent – phase	-	■	■	-	■	-	■	-	■	■
67G	Directional earth fault – measured	-	■	■	-	■	-	■	-	■	■
67GI	Directional Intermittent Earth Fault	-	■	■	-	-	-	-	-	-	-
67GS	Directional sensitive earth fault – measured	-	■	■	-	-	-	-	-	-	-
67N	Directional earth fault – calculated	-	■	■	-	■	-	■	-	■	■
74CC	Close-circuit supervision	■	■	■	■	■	■	■	■	■	■
74TC	Trip-circuit supervision	■	■	■	■	■	■	■	■	■	■
78VS	Voltage vector shift	-	■	■	-	■	-	■	-	-	-
79	Automatic reclosing	■	■	■	-	-	-	-	-	-	-
81	Frequency protection – "f>" or "f<"	-	■	■	-	■	-	■	-	■	■
81B	Backspin monitor	-	-	-	-	-	-	-	■	-	-
81B-V	Backspin monitor – voltage reference	-	-	-	-	-	-	-	-	■	■
81HB2	Inrush current detection	■	■	■	■	■	■	■	■	■	■
81HB5	Overfluxing detection – 5th harmonic	-	-	-	■	■	■	■	-	-	-
81R	Frequency protection – "df/dt"	-	■	■	-	■	-	■	-	-	-
86	Lockout	■	■	■	■	■	■	■	■	■	■
87GH	Restricted earth fault protection – high-impedance	■	■	■	■	■	■	■	■	■	■
87M	Motor differential protection	-	-	-	-	-	-	-	-	-	■
87NL	Restricted earth fault protection - low-impedance	■	■	■	■	■	■	■	-	-	-
87T-BD	Transformer differential protection – biased	-	-	-	■	■	■	■	-	-	-
87T-HS	Transformer differential protection – highset	-	-	-	■	■	■	■	-	-	-
	Measured values	■	■	■	■	■	■	■	■	■	■
	Switching-statistic counters	■	■	■	■	■	■	■	■	■	■
	Circuit-breaker wear monitoring	■	■	■	■	■	■	■	■	■	■
	Logic editor	■	■	■	■	■	■	■	■	■	■
	External trip initiation	■	■	■	■	■	■	■	■	■	■
	Control	■	■	■	■	■	■	■	■	■	■
	Fault recording of analog and binary signals	■	■	■	■	■	■	■	■	■	■
	Sequence of events recorder	5000	5000	5000	5000	5000	5000	5000	5000	5000	5000
	Motor operating records	-	-	-	-	-	-	-	■	■	■
	Security log	2048	2048	2048	2048	2048	2048	2048	2048	2048	2048
	Monitoring and supervision	■	■	■	■	■	■	■	■	■	■
	Setting groups	4	4	4	4	4	4	4	4	4	4
	Changeover of setting group	■	■	■	■	■	■	■	■	■	■

ANSI	Functions	7SR5110 Overcurrent	7SR5111 Directional Overcurrent	7SR5121 Directional Overcurrent	7SR5420 2 Winding Transformer	7SR5421 2 Winding Transformer	7SR5430 3 Winding Transformer	7SR5431 3 Winding Transformer	7SR5710 Motor	7SR5711 Motor	7SR572 Motor
	Binary inputs (max)	38	39	37	21	37	24	35	23	29	27
	Arc flash detector inputs (AFD)	0 or 3	0 or 3	0 or 3	0 or 3	0 or 3	0 or 3	0 or 3	0 or 3	0 or 3	0 or 3
	Temperature sensor inputs (TSI)	0 or 8	0 or 8	0 or 8	0 or 8	0 or 8	0 or 8	0 or 8	0 or 8	0, 8, or 16	0, 8, or 16
	Binary outputs (max) incl. healthy contact	18	20	18	10	18	10	16	12	16	14
	High speed binary outputs (HSBO)	0 or 3	0 or 3	0 or 3	0 or 3	0 or 3	0 or 3	0 or 3	0 or 3	0 or 3	0 or 3
	Current inputs	4	4	5	8	8	12	12	4	4	4
	Voltage inputs	0	4	4	0	4	0	4	0	4	4
	Size	6, 8, or 12	6, 8, or 12	8 or 12	8 or 12	8 or 12	12	12	6, 8, or 12	6, 8, or 12	8 or 12
	LCD resolution	128x128									
	Push buttons	7	7	7	7	7	7	7	7	7	7
	LEDs	28	28	28	28	28	28	28	28	28	28
	Power supply unit rated voltages	DC 24 to 250 V AC 100 to 230 V									
	Front user interface	■	■	■	■	■	■	■	■	■	■
	User selectable languages: English, French, German, Portuguese, Spanish, Turkish	■	■	■	■	■	■	■	■	■	■
	IEC 60870-5-103	■	■	■	■	■	■	■	■	■	■
	IEC 61850	■	■	■	■	■	■	■	■	■	■
	Modbus RTU	■	■	■	■	■	■	■	■	■	■
	Modbus TCP	■	■	■	■	■	■	■	■	■	■
	SNMP v3	■	■	■	■	■	■	■	■	■	■
	DNP3	■	■	■	■	■	■	■	■	■	■
	DNP3 TCP	■	■	■	■	■	■	■	■	■	■
	Time synchronization: Binary input, DNP3, Modbus RTU, DNP TCP, Modbus TCP, SNTP, IEEE 1588 PTP	■	■	■	■	■	■	■	■	■	■



NOTE

■ - Basic

Devices and Application

Application Examples – Medium Voltage

Medium-Voltage Applications for all System Grounding Types

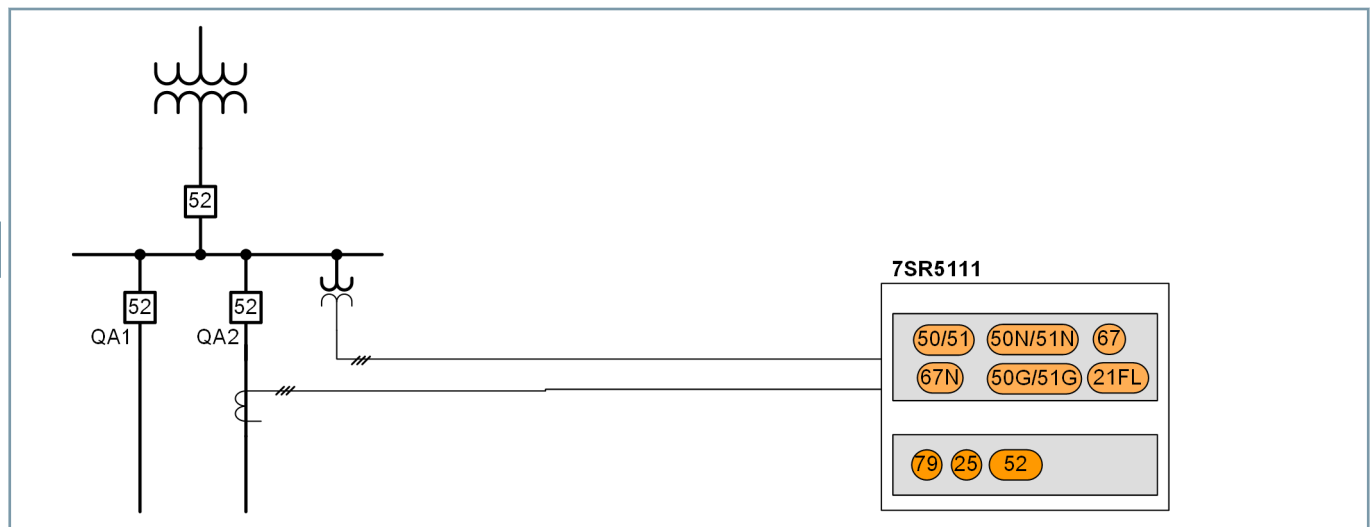

[dw_Medium-voltage appl for all sys ground typ, 4, en_US]

Figure 2.3/1 Medium-Voltage Applications for all System Grounding Types

Properties

- Reliable detection of transients and static ground faults
- Cost saving due to integrated autoreclose function
- Directional and non-directional protection and control functions

2-Winding Transformer

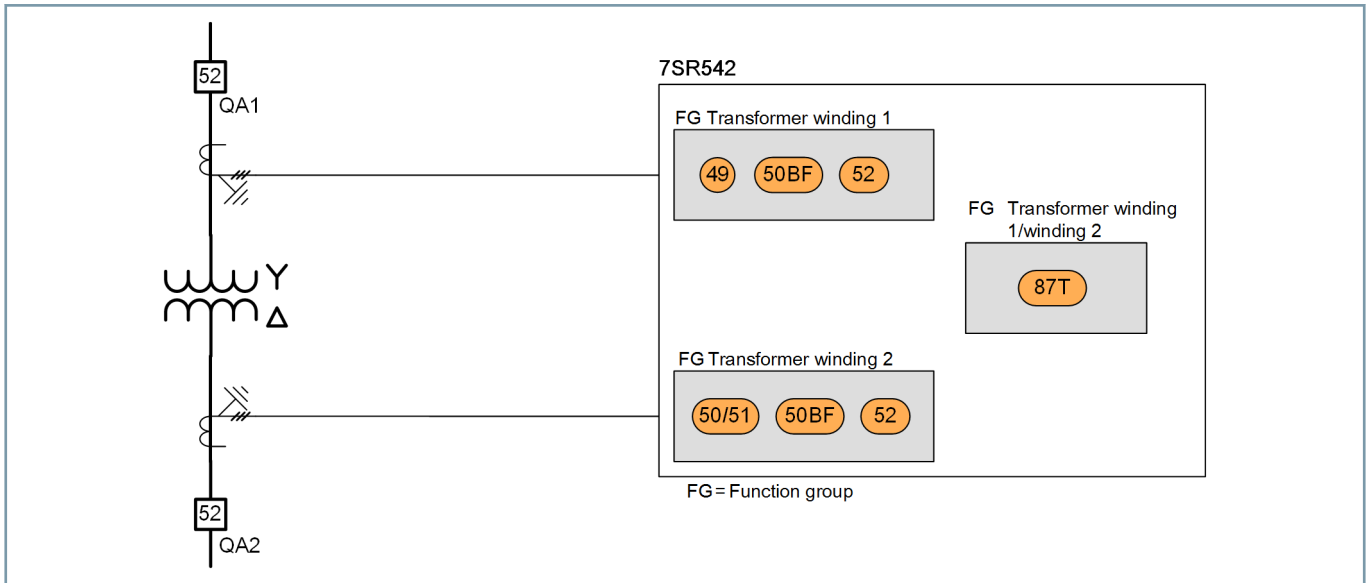

2.3

[dw_Two-winding transformer, 3, en_US]

Figure 2.3/2 2-Winding Transformer

Properties

- Clear assignment of the functions to the primary element
- Reduced investment
- Simple parameterization
- Reduced wiring and faster commissioning

Protection and Backup Protection Solution for 3-Winding Transformers

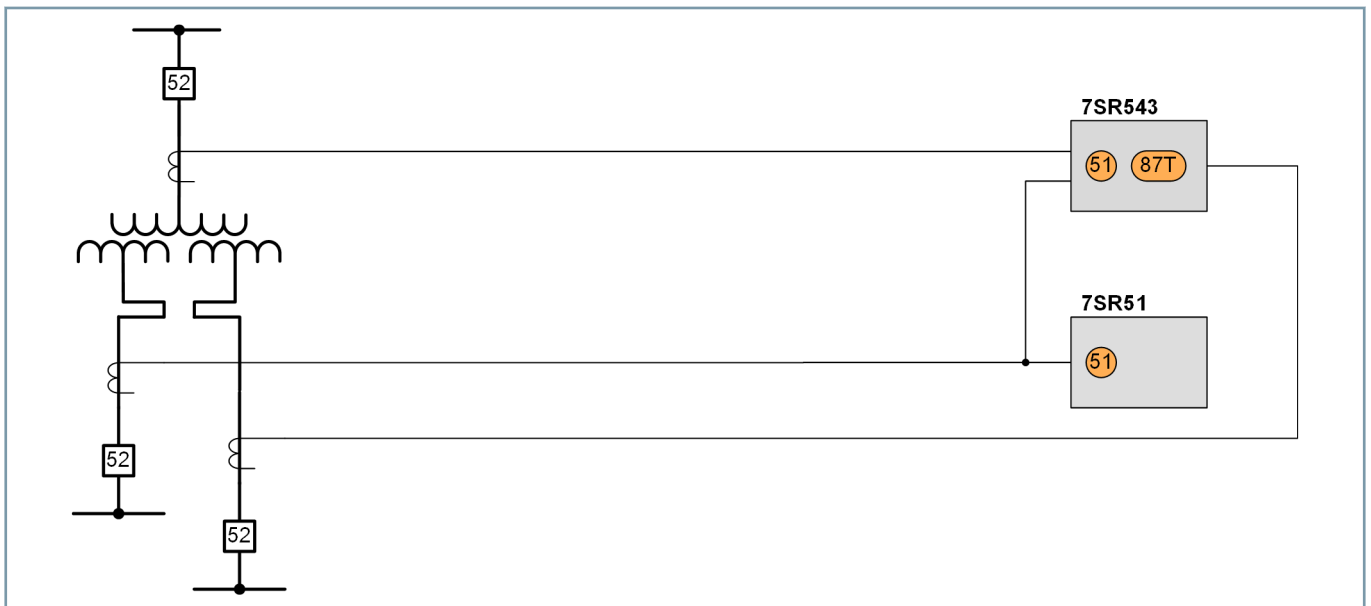

[dw_Protection and backup protection, 3, en_US]

Figure 2.3/3 Protection and Backup Protection Solution for 3-Winding Transformers

Properties

- Protection and backup protection concept
- Increased availability

Devices and Application

Application Examples – Motor Protection

Motor Protection

Induction Motor: Protection and Control

2.3

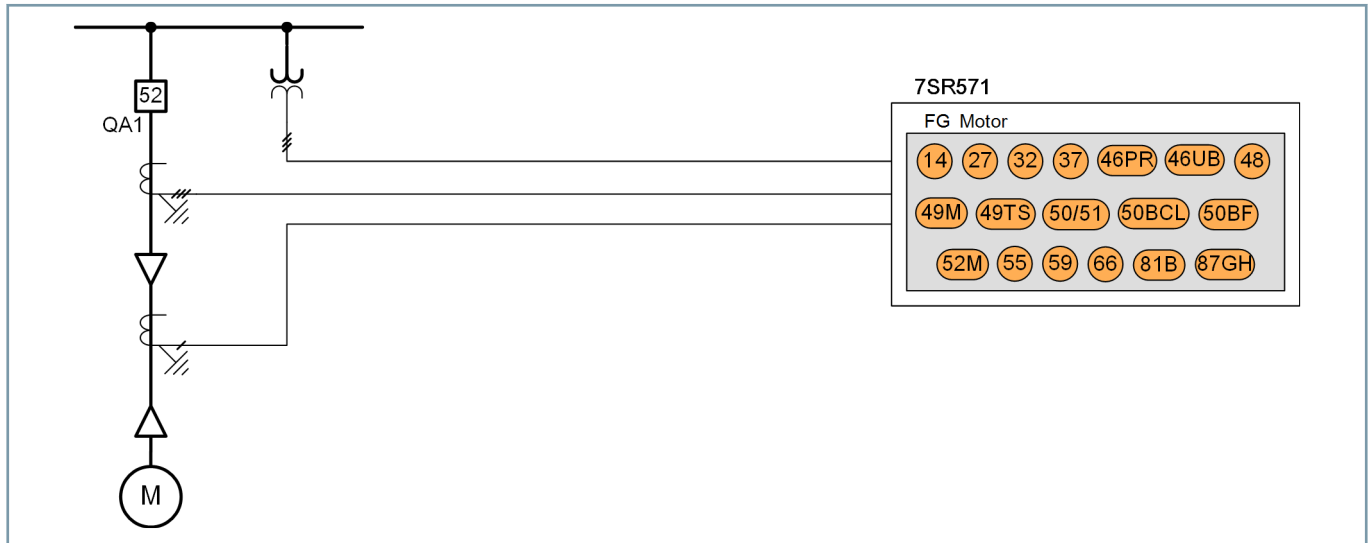

[dw_7SR5_Motor_3_en_US]

Figure 2.3/4 Induction Motor: Protection and Control

Properties

- Reduced investment due to protection and control in one device
- Thermal motor protection functions for reliable motor monitoring

- Thermal motor protection functions with direct connection of temperature sensors

Motor: Differential Protection and Control

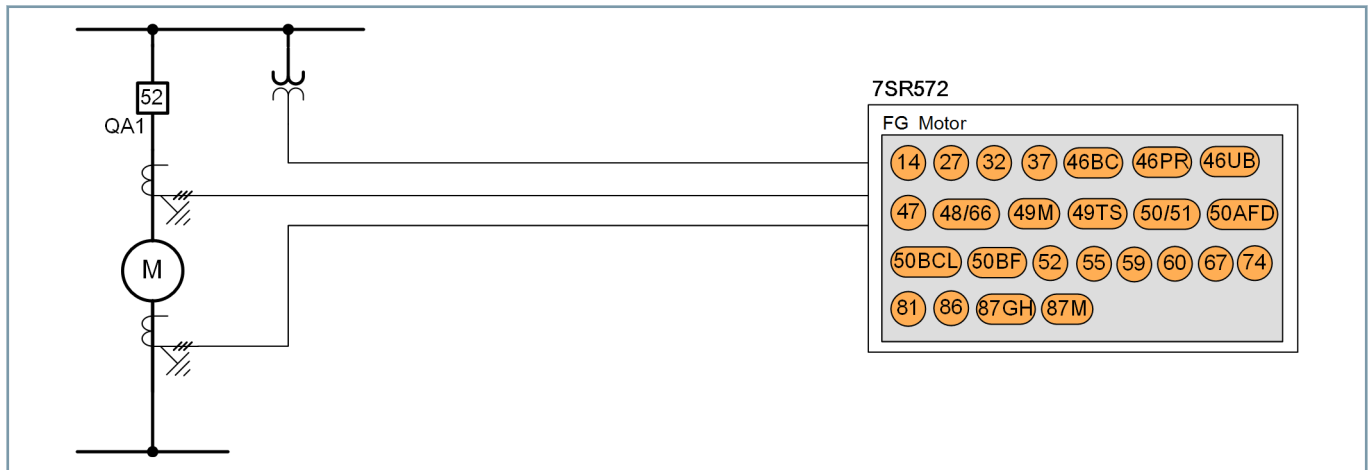

[dw_7SR5_Differential_Motor_1_en_US]

Figure 2.3/5 Motor: Differential Protection and Control

Description

The Reyrolle 5 is designed for the electricity networks of the future with enhanced communications and cyber security while maintaining a user-friendly interface and easy product management.

The Reyrolle 7SR51 overcurrent device includes a wide range of protection functions and IEC 61850 Ethernet communications as standard. To further minimize the product variants the power supply and the binary inputs cover the full operating range with configurable binary input thresholds.

The large LCD, tactile pushbuttons and programmable LEDs provide a user-friendly product interface and the relay element is withdrawable for easy replacement.



file_size6Front15%_2_1_1

Inputs and outputs	Current inputs – 4 or 5 Voltage inputs – 0 or 4 Binary inputs (max) – 39 Binary outputs (max) incl. healthy contact – 20 Arc flash detector inputs (AFD) – 0 or 3 High speed binary outputs (HSBO) – 0 or 3 Temperature sensor inputs (TSI) – 0 or 8
Communication	Standard front USB port (for configuration using Reydisp Manager 2, a PC based software tool) rear RS485, 2 x RJ45 electrical ports or optional optical Ethernet connections
Housing	Size 6, 8, or 12 with withdrawable design
Display	Backlit 128 x 128 LCD with text and graphical display capabilities suitable for single line mimic diagrams

Benefits

- Compact design and low product life-cycle cost
- Reliable operation due to powerful, proven protection algorithms
- IEC 61850 Edition 1 & 2 with HSR, PRP and RSTP operation for increased availability
- Simple product ordering
- Combined 1 A and 5 A current transformer inputs
- 28 programmable tri-color LEDs for clear indications
- User selectable languages: English, French, German, Portuguese, Spanish, Turkish
- Conformal coating ordering option

Functions

Standard Functionality

- 37/37G Undercurrent protection – phase/earth
- 46 Negative sequence overcurrent protection
- 46BC Broken conductor detection
- 49 Thermal overload protection
- 49TS Temperature sensor supervision³

- 50/50G/50N Instantaneous overcurrent/earth fault
- 50AFD Arc flash detection⁴
- 50BF Circuit-breaker failure protection – 3-pole
- 50GHS High speed earth fault – measured
- 50GI Intermittent earth fault
- 50GS Instantaneous sensitive earth fault – measured
- 50HS High speed overcurrent – phase
- 50SOTF Switch onto fault
- 51/51G/51N Time delayed overcurrent/earth fault
- 51CL Cold load overcurrent – phase
- 51GS Time-delayed sensitive earth fault – measured
- 52 Circuit-breaker control
- 60CTS CT supervision
- 74CC/74TC Close-circuit and trip-circuit supervision
- 79 Automatic reclosing
- 81HB2 Inrush current detection
- 86 Lockout
- 87GH Restricted earth fault protection – high-impedance
- 87NL Restricted earth fault protection - low-impedance

Additional Functionality – Devices with VT Inputs

- 21FL Fault locator
- 21LB Load blinder
- 25 Synchrocheck – synchronization function
- 27/27Vx Undervoltage protection
- 32 Power protection
- 47 Sequence overvoltage protection
- 51V Voltage-dependent overcurrent – phase
- 55 Power factor
- 59/59Vx Overvoltage protection
- 59N Neutral voltage displacement
- 60VTS VT supervision
- 67/67G/67GI/67GS/67N Directional – phase/earth fault

³ An external interface unit is required where optional TSI module not fitted.

⁴ Requires external components

Devices and Application

Overcurrent Protection – Reyrolle 7SR51

- 78VS Voltage vector shift
- 81 Frequency protection – "f>" or "f<"
- 81R Frequency protection – "df/dt"

Monitoring Functions

- Primary, secondary, and phase sequence, current & voltage
- Frequency, power, energy and fault location
- Fault data, event and waveform records

Applications

- Overcurrent and earth fault protection for medium voltage substations
- Backup protection for other main protection devices e.g. on lines, transformers, generators, motors, and busbars
- 5 CT model to provide measured standby earth fault for protection of transformer earthing resistors in addition to high-impedance earth fault protection

- Selectable directional overcurrent and earth fault elements for interconnected systems
- Measured and calculated earth fault protection elements provide a flexible solution when both earth fault and sensitive earth fault current detection is required
- Detection of earth faults in all networks including isolated and compensated networks
- High speed overcurrent elements for use with arc fault detectors to provide high speed fault detection and tripping
- Blocked overcurrent schemes using hardwiring or configurable IEC 61850 elements
- Configurable automatic reclosing to restore power flow after transient network faults

Communication

- IEC 60870-5-103, Modbus TCP, DNP3 TCP, Modbus RTU, DNP3, IEC 61850

2.4

Application Templates

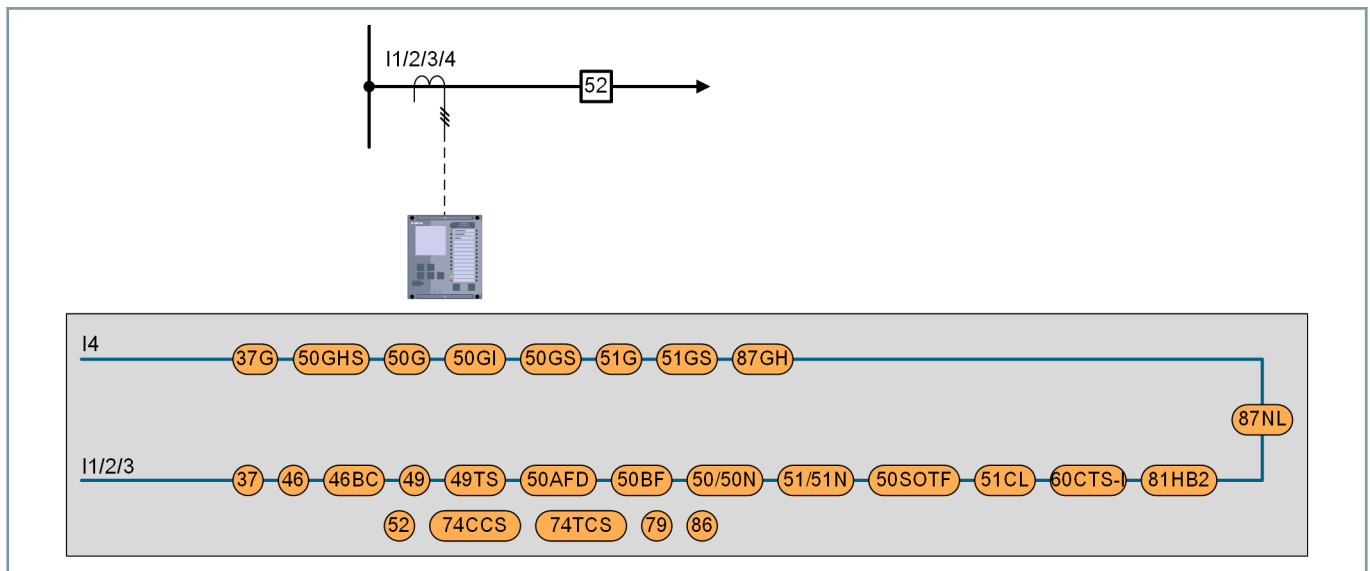

[file_7SR5_7SR51_OCEF_functiondiagram_5_en_US]

Figure 2.4/1 Function Diagram: 7SR5110 OCEF Protection

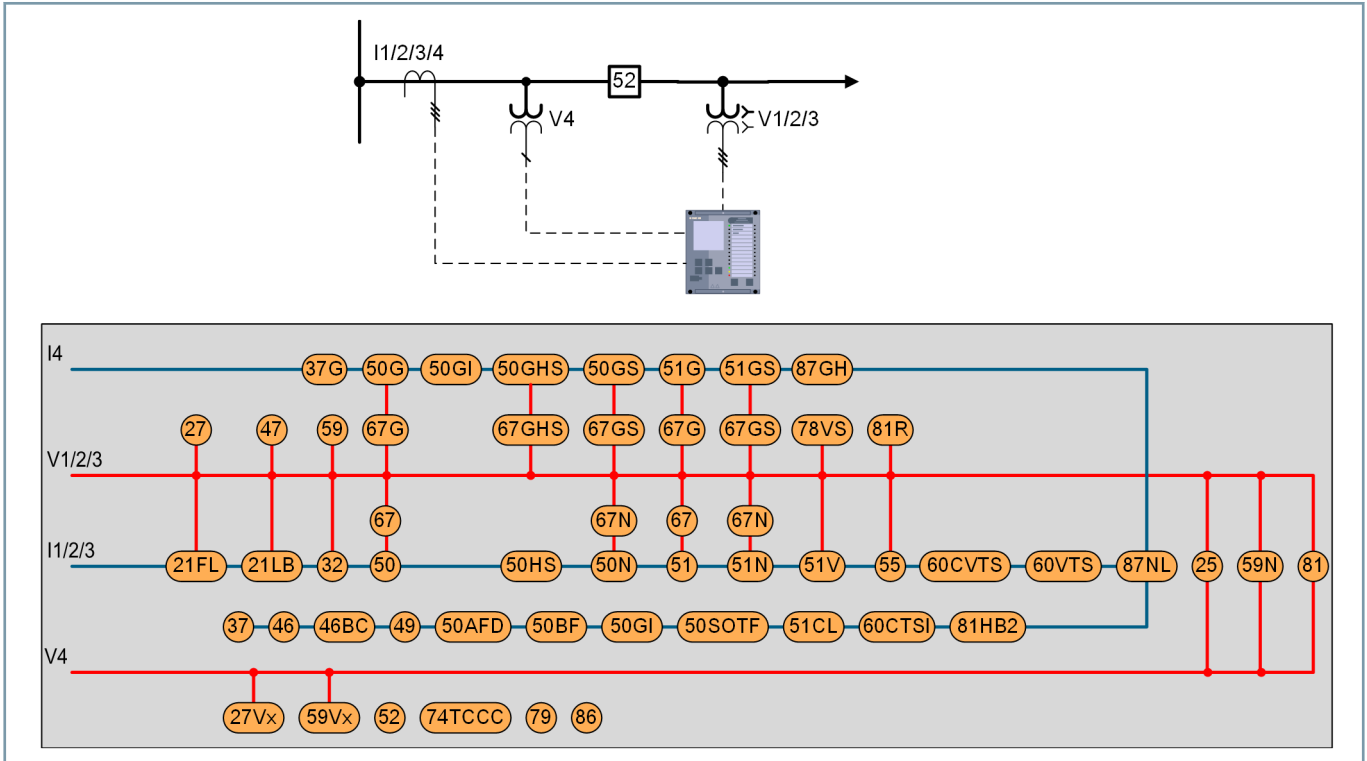

[dw_7SR5_7SR51_DOC-DEF_functiendiagram_5_en_US]

Figure 2.4/2 Function Diagram: 7SR5111 DOC/DEF Protection

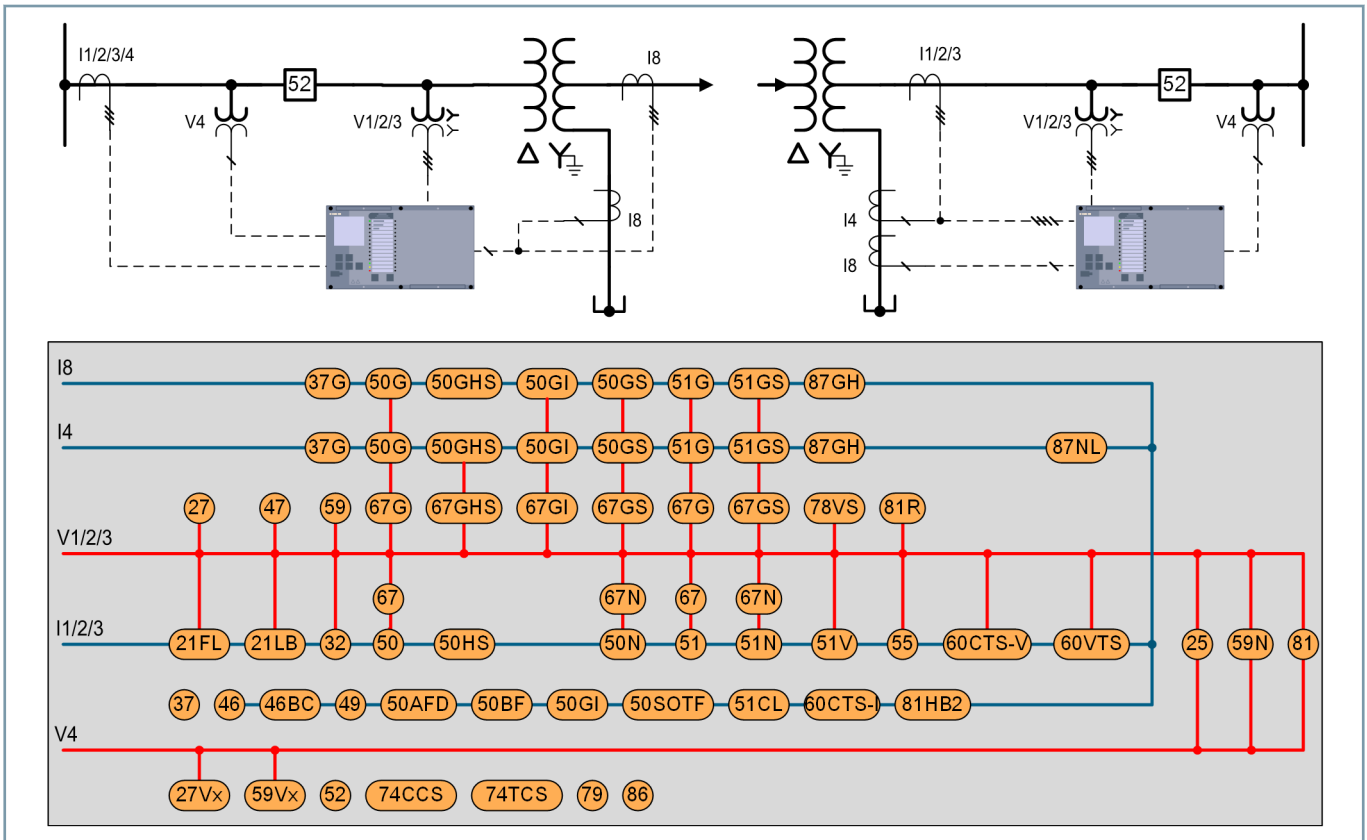

[dw_7SR5_7SR5121_txfunctiondiagram_3_en_US]

Figure 2.4/3 Function Diagram: 7SR5121 DOC/DEF Protection

Devices and Application

Overcurrent Protection – Reyrolle 7SR51

Functions, Application Templates

ANSI	Functions	7SR5110	7SR5111	7SR5121
21FL	Fault locator	–	■	■
21LB	Load blinder	–	■	■
25	Synchrocheck – synchronization function	–	■	■
27	Undervoltage protection – 3-phase	–	■	■
27Vx	Undervoltage protection – Vx	–	■	■
32	Power protection	–	■	■
37	Undercurrent protection – phase	■	■	■
37G	Undercurrent earth fault – measured	■	■	■
46	Negative sequence overcurrent protection	■	■	■
46BC	Broken conductor detection	■	■	■
47	Sequence overvoltage protection	–	■	■
49	Thermal overload protection	■	■	■
49TS	Temperature sensor supervision ⁵	■	■	■
50	Instantaneous overcurrent – phase	■	■	■
50AFD	Arc flash detection ⁶	■	■	■
50BF	Circuit-breaker failure protection – 3-pole	■	■	■
50G	Instantaneous earth fault – measured	■	■	■
50GHS	High speed earth fault – measured	■	■	■
50GI	Intermittent earth fault	■	■	■
50GS	Instantaneous sensitive earth fault – measured	■	■	■
50HS	High speed overcurrent – phase	■	■	■
50N	Instantaneous earth fault – calculated	■	■	■
50SOTF	Switch onto fault	■	■	■
51	Time-delayed overcurrent – phase	■	■	■
51CL	Cold load overcurrent – phase	■	■	■
51G	Time delayed earth fault – measured	■	■	■
51GS	Time-delayed sensitive earth fault – measured	■	■	■
51N	Time-delayed earth fault – calculated	■	■	■
51V	Voltage-dependent overcurrent – phase	–	■	■
52	Circuit-breaker control	■	■	■
55	Power factor	–	■	■
59	Overvoltage protection – 3-phase	–	■	■
59N	Neutral voltage displacement	–	■	■
59Vx	Overvoltage protection – Vx	–	■	■
60CTS-I	CT supervision – current reference	■	■	■
60CTS-V	CT supervision – voltage reference	–	■	■
60VTS	VT supervision	–	■	■
67	Directional overcurrent – phase	–	■	■
67G	Directional earth fault – measured	–	■	■
67GI	Directional Intermittent Earth Fault	–	■	■
67GS	Directional sensitive earth fault – measured	–	■	■
67N	Directional earth fault – calculated	–	■	■
74CC	Close-circuit supervision	■	■	■
74TC	Trip-circuit supervision	■	■	■
78VS	Voltage vector shift	–	■	■
79	Automatic reclosing	■	■	■
81	Frequency protection – "f>" or "f<"	–	■	■
81HB2	Inrush current detection	■	■	■

⁵ An external interface unit is required where optional TSI module not fitted.

⁶ Requires external components

ANSI	Functions	7SR5110	7SR5111	7SR5121
81R	Frequency protection – "df/dt"	–	■	■
86	Lockout	■	■	■
87GH	Restricted earth fault protection – high-impedance	■	■	■
87NL	Restricted earth fault protection - low-impedance	■	■	■
	Measured values	■	■	■
	Switching-statistic counters	■	■	■
	Circuit-breaker wear monitoring	■	■	■
	Logic editor	■	■	■
	External trip initiation	■	■	■
	Control	■	■	■
	Fault recording of analog and binary signals	■	■	■
	Sequence of events recorder	5000	5000	5000
	Security log	2048	2048	2048
	Monitoring and supervision	■	■	■
	Setting groups	4	4	4
	Changeover of setting group	■	■	■
	Binary inputs (max)	38	39	37
	Arc flash detector inputs (AFD)	0 or 3	0 or 3	0 or 3
	Temperature sensor inputs (TSI)	0 or 8	0 or 8	0 or 8
	Binary outputs (max) incl. healthy contact	18	20	18
	High speed binary outputs (HSBO)	0 or 3	0 or 3	0 or 3
	Current inputs	4	4	5
	Voltage inputs	0	4	4
	Size	6, 8, or 12	6, 8, or 12	8 or 12
	LCD resolution	128x128		
	Push buttons	7	7	7
	LEDs	28	28	28
	Power supply unit rated voltages	DC 24 to 250 V AC 100 to 230 V		
	Front user interface	■	■	■
	User selectable languages: English, French, German, Portuguese, Spanish, Turkish	■	■	■
	IEC 60870-5-103	■	■	■
	IEC 61850	■	■	■
	Modbus RTU	■	■	■
	Modbus TCP	■	■	■
	SNMP v3	■	■	■
	DNP3	■	■	■
	DNP3 TCP	■	■	■
	Time synchronization: Binary input, DNP3, Modbus RTU, DNP TCP, Modbus TCP, SNTP, IEEE 1588 PTP	■	■	■

Table 2.4/1 Reyrolle 7SR51 – Functions and Application Templates









NOTE

■ - Basic

Devices and Application

Overcurrent Protection – Reyrolle 7SR51

Standard Variants

Standard Variants for 7SR511		
7SR5110-1AA	3/8, 8 BI, 6 BO, 4 I Housing width 3/8 x 19" (size 6), housing height 4U 8 binary inputs 6 binary outputs (1 break, 2 changeover, 3 make) 4 current transformer inputs Communication: USB, RS485, 2 x Ethernet	
7SR5110-1AD	3/8, 8 BI, 9 BO (inc. 3 HSBO), 4 I, 3 AFD Housing width 3/8 x 19" (size 6), housing height 4U 8 binary inputs 9 binary outputs (1 break, 2 changeover, 6 make) 4 current transformer inputs Communication: USB, RS485, 2 x Ethernet	
7SR5110-2AA	3/8, 13 BI, 8 BO, 4 I Housing width 3/8 x 19" (size 6), housing height 4U 13 binary inputs 8 binary outputs (1 break, 2 changeover, 5 make) 4 current transformer inputs Communication: USB, RS485, 2 x Ethernet	
7SR5110-2AD	3/8, 13 BI, 11 BO (inc. 3 HSBO), 4 I, 3 AFD Housing width 3/8 x 19" (size 6), housing height 4U 13 binary inputs 11 binary outputs (1 break, 2 changeover, 8 make) 4 current transformer inputs Communication: USB, RS485, 2 x Ethernet	
7SR5110-2AF	3/8, 13 BI, 8 BO, 4 I, 8 TSI Housing width 3/8 x 19" (size 6), housing height 4U 13 binary inputs 8 binary outputs (1 break, 2 changeover, 5 make) 4 current transformer inputs Communication: USB, RS485, 2 x Ethernet	
7SR5110-3AA	1/2, 18 BI, 10 BO, 4 I Housing width 1/2 x 19" (size 8), housing height 4U 18 binary inputs 10 binary outputs (1 break, 2 changeover, 7 make) 4 current transformer inputs Communication: USB, RS485, 2 x Ethernet	
7SR5110-3AD	1/2, 18 BI, 13 BO (inc. 3 HSBO), 4 I, 3 AFD Housing width 1/2 x 19" (size 8), housing height 4U 18 binary inputs 13 binary outputs (1 break, 2 changeover, 10 make) 4 current transformer inputs Communication: USB, RS485, 2 x Ethernet	

2.4

7SR5110-3AF	1/2, 18 BI, 10 BO, 4 I, 8 TSI Housing width 1/2 x 19" (size 8), housing height 4U 18 binary inputs 10 binary outputs (1 break, 2 changeover, 7 make) 4 current transformer inputs Communication: USB, RS485, 2 x Ethernet	
7SR5110-4AA	1/2, 23 BI, 12 BO, 4 I Housing width 1/2 x 19" (size 8), housing height 4U 23 binary inputs 12 binary outputs (1 break, 2 changeover, 9 make) 4 current transformer inputs Communication: USB, RS485, 2 x Ethernet	
7SR5110-4AA	3/4, 23 BI, 12 BO, 4 I Housing width 3/4 x 19" (size 12), housing height 4U 23 binary inputs 12 binary outputs (1 break, 2 changeover, 9 make) 4 current transformer inputs Communication: USB, RS485, 2 x Ethernet	
7SR5110-4AD	1/2, 23 BI, 15 BO (inc. 3 HSBO), 4 I, 3 AFD Housing width 1/2 x 19" (size 8), housing height 4U 23 binary inputs 15 binary outputs (1 break, 2 changeover, 12 make) 4 current transformer inputs Communication: USB, RS485, 2 x Ethernet	
7SR5110-4AF	1/2, 23 BI, 12 BO, 4 I, 8 TSI Housing width 1/2 x 19" (size 8), housing height 4U 23 binary inputs 12 binary outputs (1 break, 2 changeover, 9 make) 4 current transformer inputs Communication: USB, RS485, 2 x Ethernet	
7SR5110-7AA	3/4, 38 BI, 18 BO, 4 I Housing width 3/4 x 19" (size 12), housing height 4U 38 binary inputs 18 binary outputs (1 break, 2 changeover, 15 make) 4 current transformer inputs Communication: USB, RS485, 2 x Ethernet	
7SR5111-1AA	3/8, 9 BI, 8 BO, 4 I, 4 V Housing width 3/8 x 19" (size 6), housing height 4U 9 binary inputs 8 binary outputs (1 break, 2 changeover, 5 make) 4 current transformer inputs 4 voltage transformer inputs Communication: USB, RS485, 2 x Ethernet	

Devices and Application

Overcurrent Protection – Reyrolle 7SR51

2.4

7SR5111-1AD	3/8, 9 BI, 11 BO (inc. 3 HSBO), 4 I, 4 V, 3 AFD Housing width 3/8 x 19" (size 6), housing height 4U 9 binary inputs 11 binary outputs (1 break, 2 changeover, 8 make) 4 current transformer inputs 4 voltage transformer inputs Communication: USB, RS485, 2 x Ethernet	
7SR5111-1AF	3/8, 9 BI, 8 BO, 4 I, 4 V, 8 TSI Housing width 3/8 x 19" (size 6), housing height 4U 9 binary inputs 8 binary outputs (1 break, 2 changeover, 5 make) 4 current transformer inputs 4 voltage transformer inputs Communication: USB, RS485, 2 x Ethernet	
7SR5111-2AA	1/2, 14 BI, 10 BO, 4 I, 4 V Housing width 1/2 x 19" (size 8), housing height 4U 14 binary inputs 10 binary outputs (1 break, 2 changeover, 7 make) 4 current transformer inputs 4 voltage transformer inputs Communication: USB, RS485, 2 x Ethernet	
7SR5111-2AA	3/4, 14 BI, 10 BO, 4 I, 4 V Housing width 3/4 x 19" (size 12), housing height 4U 14 binary inputs 10 binary outputs (1 break, 2 changeover, 7 make) 4 current transformer inputs 4 voltage transformer inputs Communication: USB, RS485, 2 x Ethernet	
7SR5111-3AA	1/2, 19 BI, 12 BO, 4 I, 4 V Housing width 1/2 x 19" (size 8), housing height 4U 19 binary inputs 12 binary outputs (1 break, 2 changeover, 9 make) 4 current transformer inputs 4 voltage transformer inputs Communication: USB, RS485, 2 x Ethernet	
7SR5111-3AA	3/4, 19 BI, 12 BO, 4 I, 4 V Housing width 3/4 x 19" (size 12), housing height 4U 19 binary inputs 12 binary outputs (1 break, 2 changeover, 9 make) 4 current transformer inputs 4 voltage transformer inputs Communication: USB, RS485, 2 x Ethernet	
7SR5111-3AD	1/2, 19 BI, 15 BO (inc. 3 HSBO), 4 I, 4 V, 3 AFD Housing width 1/2 x 19" (size 8), housing height 4U 19 binary inputs 15 binary outputs (1 break, 2 changeover, 12 make) 4 current transformer inputs 4 voltage transformer inputs Communication: USB, RS485, 2 x Ethernet	

<p>7SR5111-3AD</p>	<p>3/4, 19 BI, 15 BO (inc. 3 HSBO), 4 I, 4 V, 3 AFD</p> <p>Housing width 3/4 x 19" (size 12), housing height 4U</p> <p>19 binary inputs</p> <p>15 binary outputs (1 break, 2 changeover, 12 make)</p> <p>4 current transformer inputs</p> <p>4 voltage transformer inputs</p> <p>Communication: USB, RS485, 2 x Ethernet</p>	
<p>7SR5111-3AF</p>	<p>1/2, 19 BI, 12 BO, 4 I, 4 V, 8 TSI</p> <p>Housing width 1/2 x 19" (size 8), housing height 4U</p> <p>19 binary inputs</p> <p>12 binary outputs (1 break, 2 changeover, 9 make)</p> <p>4 current transformer inputs</p> <p>4 voltage transformer inputs</p> <p>Communication: USB, RS485, 2 x Ethernet</p>	
<p>7SR5111-4AA</p>	<p>3/4, 24 BI, 14 BO, 4 I, 4 V</p> <p>Housing width 3/4 x 19" (size 12), housing height 4U</p> <p>24 binary inputs</p> <p>14 binary outputs (1 break, 2 changeover, 11 make)</p> <p>4 current transformer inputs</p> <p>4 voltage transformer inputs</p> <p>Communication: USB, RS485, 2 x Ethernet</p>	
<p>7SR5111-4AD</p>	<p>3/4, 24 BI, 17 BO (inc. 3 HSBO), 4 I, 4 V, 3 AFD</p> <p>Housing width 3/4 x 19" (size 12), housing height 4U</p> <p>24 binary inputs</p> <p>17 binary outputs (1 break, 2 changeover, 14 make)</p> <p>4 current transformer inputs</p> <p>4 voltage transformer inputs</p> <p>Communication: USB, RS485, 2 x Ethernet</p>	
<p>7SR5111-7AA</p>	<p>3/4, 39 BI, 20 BO, 4 I, 4 V</p> <p>Housing width 3/4 x 19" (size 12), housing height 4U</p> <p>39 binary inputs</p> <p>20 binary outputs (1 break, 2 changeover, 17 make)</p> <p>4 current transformer inputs</p> <p>4 voltage transformer inputs</p> <p>Communication: USB, RS485, 2 x Ethernet</p>	
<p>7SR5111-7AD</p>	<p>3/4, 39 BI, 23 BO (inc. 3 HSBO), 4 I, 4 V, 3 AFD</p> <p>Housing width 3/4 x 19" (size 12), housing height 4U</p> <p>39 binary inputs</p> <p>23 binary outputs (1 break, 2 changeover, 20 make)</p> <p>4 current transformer inputs</p> <p>4 voltage transformer inputs</p> <p>Communication: USB, RS485, 2 x Ethernet</p>	
<p>7SR5111-7AF</p>	<p>3/4, 39 BI, 20 BO, 4 I, 4 V, 8 TSI</p> <p>Housing width 3/4 x 19" (size 12), housing height 4U</p> <p>39 binary inputs</p> <p>20 binary outputs (1 break, 2 changeover, 17 make)</p> <p>4 current transformer inputs</p> <p>4 voltage transformer inputs</p> <p>Communication: USB, RS485, 2 x Ethernet</p>	

Devices and Application

Overcurrent Protection – Reyrolle 7SR51

2.4

7SR5121-2AA	1/2, 17 BI, 10 BO, 5 I, 4 V Housing width 1/2 x 19" (size 8), housing height 4U 17 binary inputs 10 binary outputs (1 break, 2 changeover, 7 make) 5 current transformer inputs 4 voltage transformer inputs Communication: USB, RS485, 2 x Ethernet	
7SR5121-2AA	3/4, 17 BI, 10 BO, 5 I, 4 V Housing width 3/4 x 19" (size 12), housing height 4U 17 binary inputs 10 binary outputs (1 break, 2 changeover, 7 make) 5 current transformer inputs 4 voltage transformer inputs Communication: USB, RS485, 2 x Ethernet	
7SR5121-3AA	3/4, 22 BI, 12 BO, 5 I, 4 V Housing width 3/4 x 19" (size 12), housing height 4U 22 binary inputs 12 binary outputs (1 break, 2 changeover, 9 make) 5 current transformer inputs 4 voltage transformer inputs Communication: USB, RS485, 2 x Ethernet	
7SR5121-3AD	3/4, 22 BI, 15 BO (inc. 3 HSBO), 5 I, 4 V, 3 AFD Housing width 3/4 x 19" (size 12), housing height 4U 22 binary inputs 15 binary outputs (1 break, 2 changeover, 12 make) 5 current transformer inputs 4 voltage transformer inputs Communication: USB, RS485, 2 x Ethernet	
7SR5121-6AA	3/4, 37 BI, 18 BO, 5 I, 4 V Housing width 3/4 x 19" (size 12), housing height 4U 37 binary inputs 18 binary outputs (1 break, 2 changeover, 15 make) 5 current transformer inputs 4 voltage transformer inputs Communication: USB, RS485, 2 x Ethernet	
7SR5121-6AD	3/4, 37 BI, 21 BO (inc. 3 HSBO), 5 I, 4 V, 3 AFD Housing width 3/4 x 19" (size 12), housing height 4U 37 binary inputs 21 binary outputs (1 break, 2 changeover, 18 make) 5 current transformer inputs 4 voltage transformer inputs Communication: USB, RS485, 2 x Ethernet	

7SR5121-6AF	<p>3/4, 37 BI, 18 BO, 5 I, 4 V, 8 TSI</p> <p>Housing width 3/4 x 19" (size 12), housing height 4U</p> <p>37 binary inputs</p> <p>18 binary outputs (1 break, 2 changeover, 15 make)</p> <p>5 current transformer inputs</p> <p>4 voltage transformer inputs</p> <p>Communication: USB, RS485, 2 x Ethernet</p>	
-------------	--	---

Table 2.4/2 Standard Variants for 7SR51

The technical data of the devices can be found in the hardware manual.

Devices and Application

Transformer Differential Protection – Reyrolle 7SR54

Description

The Reyrolle 5 is designed for the electricity networks of the future with enhanced communications and cyber security while maintaining a user-friendly interface and easy product management.

The Reyrolle 7SR54 provides protection, control and monitoring for 2- and 3-winding transformers. All transformer vector groups and earthing connections are supported.

The Reyrolle 7SR54 device includes a wide range of protection functions and IEC 61850 Ethernet communications as standard. To further minimize the product variants the power supply and the binary inputs cover the full operating range with configurable binary input thresholds.

The large LCD, tactile pushbuttons and programmable LEDs provide a user-friendly product interface and the relay element is withdrawable for easy replacement.



[pic_size12Front15%, 2, ...]

2.5

Inputs and outputs	Current inputs – 8 or 12 Voltage inputs – 0 or 4 Binary inputs (max) – 37 Binary outputs (max) incl. healthy contact – 18 Arc flash detector inputs (AFD) – 0 or 3 High speed binary outputs (HSBO) – 0 or 3 Temperature sensor inputs (TSI) – 0 or 8
Communication	Standard front USB port (for configuration using Reydisp Manager 2, a PC based software tool) rear RS485, 2 x RJ45 electrical ports or optional optical Ethernet connections
Housing	Size 8 or 12 with withdrawable design
Display	Backlit 128 x 128 LCD with text and graphical display capabilities suitable for single line mimic diagrams

Benefits

- Compact design and low product life-cycle cost
- Reliable operation due to powerful, proven protection algorithms
- IEC 61850 Edition 1 & 2 – with HSR, PRP and RSTP operation for increased availability
- Simple product ordering
- Combined 1 A and 5 A current transformer inputs
- 28 programmable tri-color LEDs for clear indications
- User selectable languages: English, French, German, Portuguese, Spanish, Turkish
- Conformal coating ordering option

Functions

Standard Functionality

- 37/37G Undercurrent protection – phase/earth
- 46 Negative sequence overcurrent protection
- 46BC Broken conductor detection

- 49 Thermal overload protection
- 49TS Temperature sensor supervision ⁷
- 50/50G/50N Instantaneous overcurrent/earth fault
- 50AFD Arc flash detection ⁸
- 50BF Circuit-breaker failure protection – 3-pole
- 51/51G/51N Time delayed overcurrent/earth fault
- 51CL Cold load overcurrent – phase
- 52 Circuit-breaker control
- 60CTS CT supervision
- 74CC/74TC Close-circuit and trip-circuit supervision
- 81HB2 Inrush current detection
- 81HB5 Overfluxing detection – 5th harmonic
- 86 Lockout
- 87GH Restricted earth fault protection – high-impedance
- 87NL Restricted earth fault protection - low-impedance
- 87T-BD Transformer differential protection – biased
- 87T-HS Transformer differential protection – highset

Additional Functionality – Devices with VT Inputs

- 21LB Load blinder (7SR5421)
- 24 Overexcitation protection
- 25 Synchrocheck – synchronization function
- 27/27Vx Undervoltage protection
- 32 Power protection
- 47 Sequence overvoltage protection
- 51V Voltage-dependent overcurrent – phase (7SR5421)
- 55 Power factor
- 59/59Vx Overvoltage protection
- 59N Neutral voltage displacement
- 60VTS VT supervision
- 67/67G/67N Directional – phase/earth fault (7SR5421)
- 78VS Voltage vector shift

⁷ An external interface unit is required where optional TSI module not fitted.

⁸ Requires external components

- 81 Frequency protection – "f>" or "f<"
- 81R Frequency protection – "df/dt"

Monitoring Functions

- Primary, secondary, and phase sequence, current & voltage
- Frequency, power
- Fault data, event and waveform records
- Event records (selectable events viewable on fascia)

Applications

- Comprehensive protection for 2- or 3-winding transformers.
- Differential protection for auto-transformers, reactors and motors.

Communication

- IEC 60870-5-103, Modbus TCP, DNP3 TCP
Modbus RTU, DNP3, IEC 61850

Application Templates

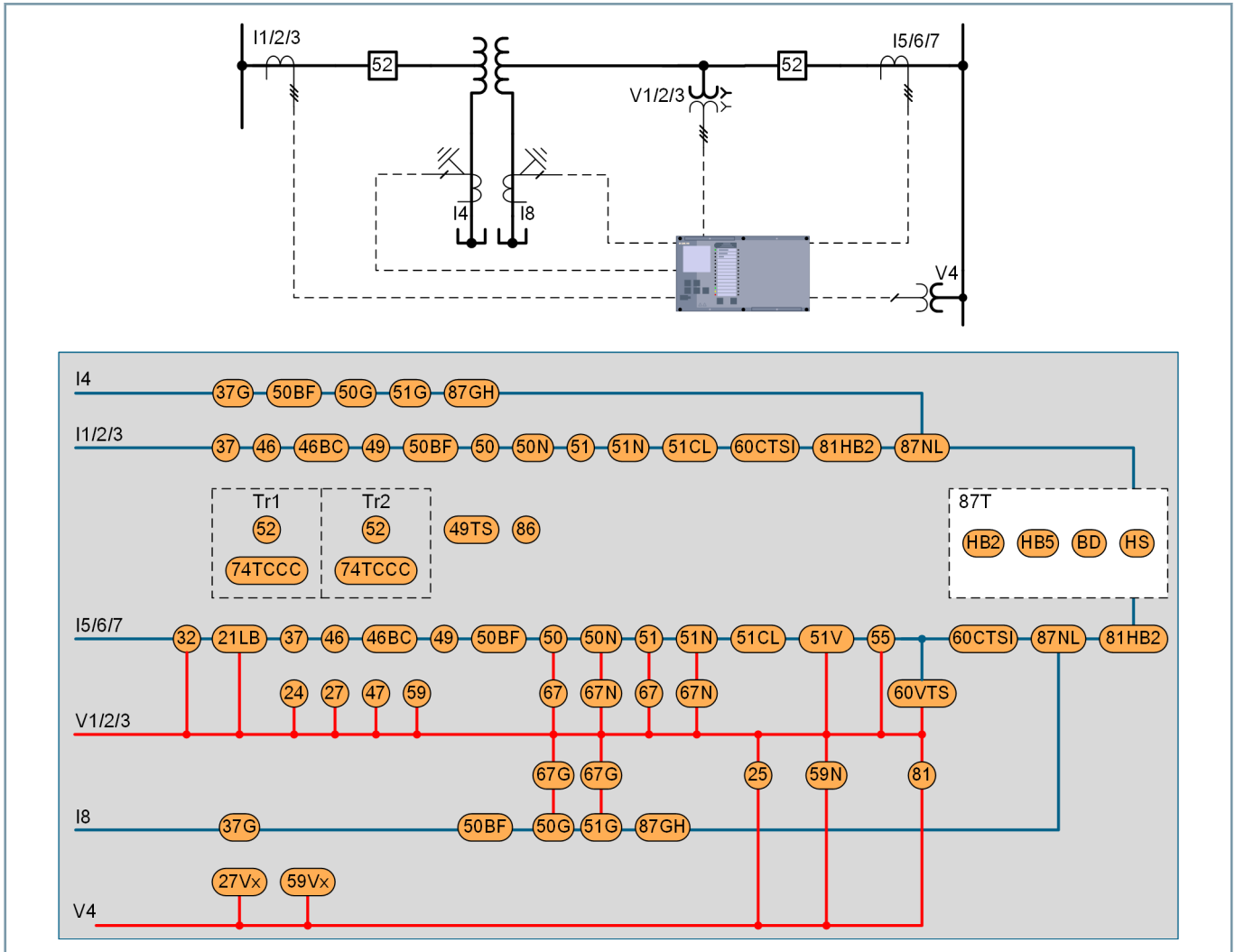

Figure 2.5/1 7SR5421 2-Winding Transformer Protection Function Diagram

VT1,2,3 shown assigned to winding 2

Devices and Application

Transformer Differential Protection – Reyrolle 7SR54

2.5

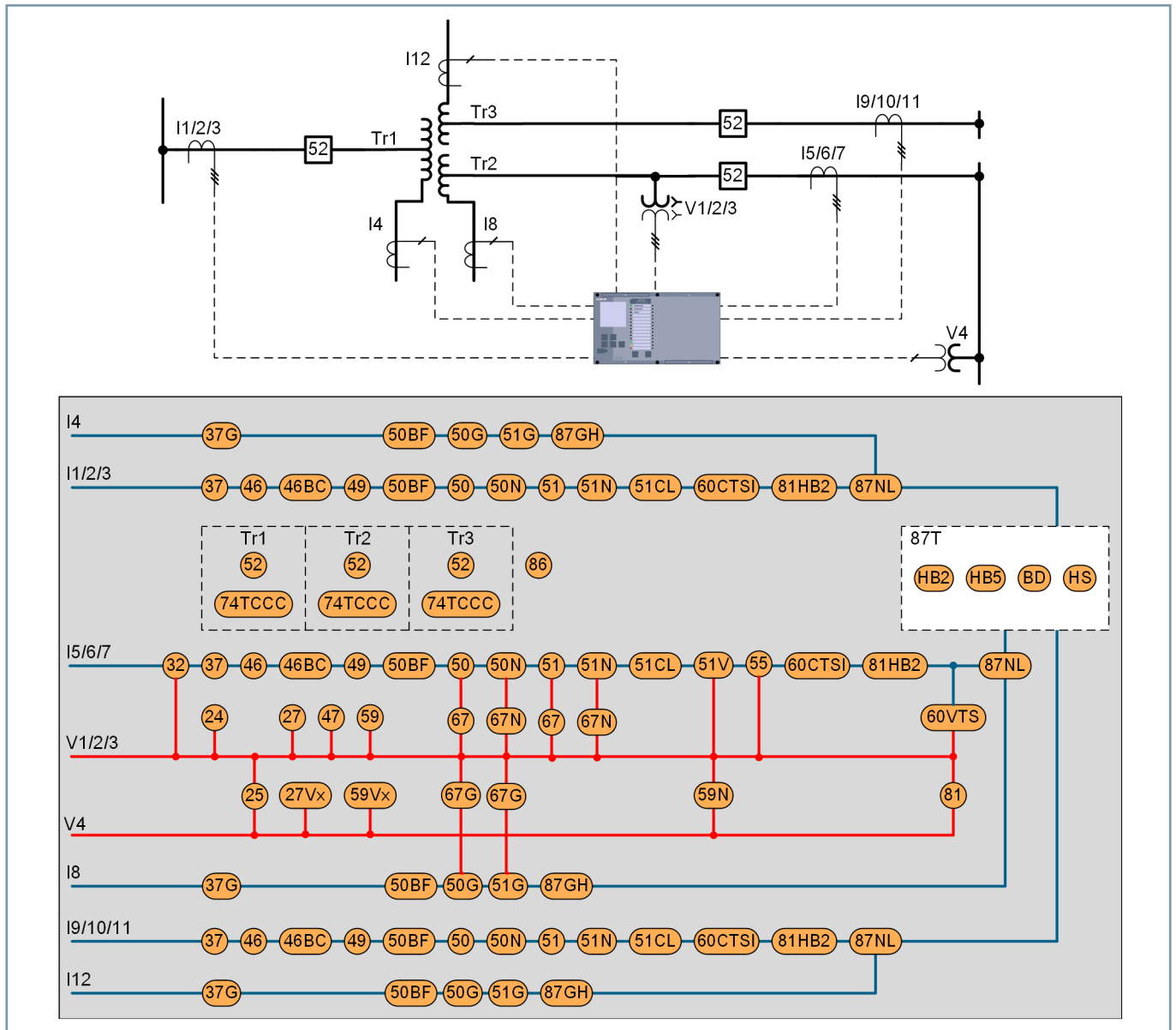

[dw_7SR5_7SR54_3winding_functiendiagram, 5, en_US]

Figure 2.5/2 7SR5431 3-Winding Transformer Protection Function Diagram

VT1,2,3 shown assigned to winding 2

Functions, Application Templates

ANSI	Functions	7SR5420	7SR5421	7SR5430	7SR5431
21LB	Load blinder	–	■	–	■
24	Overexcitation protection	–	■	–	■
25	Synchrocheck – synchronization function	–	■	–	■
27	Undervoltage protection – 3-phase	–	■	–	■
27Vx	Undervoltage protection – Vx	–	■	–	■
32	Power protection	–	■	–	■
37	Undercurrent protection – phase	■	■	■	■
37G	Undercurrent earth fault – measured	■	■	■	■
46	Negative sequence overcurrent protection	■	■	■	■
46BC	Broken conductor detection	■	■	■	■
47	Sequence overvoltage protection	–	■	–	■
49	Thermal overload protection	■	■	■	■
49TS	Temperature sensor supervision ⁹	■	■	■	■
50	Instantaneous overcurrent – phase	■	■	■	■
50AFD	Arc flash detection ¹⁰	■	■	■	■
50BF	Circuit-breaker failure protection – 3-pole	■	■	■	■
50G	Instantaneous earth fault – measured	■	■	■	■
50N	Instantaneous earth fault – calculated	■	■	■	■
51	Time-delayed overcurrent – phase	■	■	■	■
51CL	Cold load overcurrent – phase	■	■	■	■
51G	Time delayed earth fault – measured	■	■	■	■
51N	Time-delayed earth fault – calculated	■	■	■	■
51V	Voltage-dependent overcurrent – phase	–	■	–	■
52	Circuit-breaker control	■	■	■	■
55	Power factor	–	■	–	■
59	Overvoltage protection – 3-phase	–	■	–	■
59N	Neutral voltage displacement	–	■	–	■
59Vx	Overvoltage protection – Vx	–	■	–	■
60CTS-I	CT supervision – current reference	■	■	■	■
60VTS	VT supervision	–	■	–	■
67	Directional overcurrent – phase	–	■	–	■
67G	Directional earth fault – measured	–	■	–	■
67N	Directional earth fault – calculated	–	■	–	■
74CC	Close-circuit supervision	■	■	■	■
74TC	Trip-circuit supervision	■	■	■	■
78VS	Voltage vector shift	–	■	–	■
81	Frequency protection – "f>" or "f<"	–	■	–	■
81HB2	Inrush current detection	■	■	■	■
81HB5	Overfluxing detection – 5th harmonic	■	■	■	■
81R	Frequency protection – "df/dt"	–	■	–	■
86	Lockout	■	■	■	■
87GH	Restricted earth fault protection – high-impedance	■	■	■	■
87NL	Restricted earth fault protection - low-impedance	■	■	■	■
87T-BD	Transformer differential protection – biased	■	■	■	■
87T-HS	Transformer differential protection – highset	■	■	■	■
	Measured values	■	■	■	■
	Switching-statistic counters	■	■	■	■
	Circuit-breaker wear monitoring	■	■	■	■

⁹ An external interface unit is required where optional TSI module not fitted.

¹⁰ Requires external components

Devices and Application

Transformer Differential Protection – Reyrolle 7SR54

ANSI	Functions	7SR5420	7SR5421	7SR5430	7SR5431
	Logic editor	■	■	■	■
	External trip initiation	■	■	■	■
	Control	■	■	■	■
	Fault recording of analog and binary signals	■	■	■	■
	Sequence of events recorder	5000	5000	5000	5000
	Security log	2048	2048	2048	2048
	Monitoring and supervision	■	■	■	■
	Setting groups	4	4	4	4
	Changeover of setting group	■	■	■	■
	Binary inputs (max)	21	37	24	35
	Arc flash detector inputs (AFD)	0 or 3	0 or 3	0 or 3	0 or 3
	Temperature sensor inputs (TSI)	0 or 8	0 or 8	0 or 8	0 or 8
	Binary outputs (max) incl. healthy contact	10	18	10	16
	High speed binary outputs (HSBO)	0 or 3	0 or 3	0 or 3	0 or 3
	Current inputs	8	8	12	12
	Voltage inputs	0	4	0	4
	Size	8 or 12	8 or 12	12	12
	LCD resolution	128x128			
	Push buttons	7	7	7	7
	LEDs	28	28	28	28
	Power supply unit rated voltages	DC 24 to 250 V AC 100 to 230 V			
	Front user interface	■	■	■	■
	User selectable languages: English, French, German, Portuguese, Spanish, Turkish	■	■	■	■
	IEC 60870-5-103	■	■	■	■
	IEC 61850	■	■	■	■
	Modbus RTU	■	■	■	■
	Modbus TCP	■	■	■	■
	SNMP v3	■	■	■	■
	DNP3	■	■	■	■
	DNP3 TCP	■	■	■	■
	Time synchronization: Binary input, DNP3, Modbus RTU, DNP TCP, Modbus TCP, SNTP, IEEE 1588 PTP	■	■	■	■

Table 2.5/1 Reyrolle 7SR54 – Functions and Application Templates



NOTE

■ - Basic

Standard Variants

Standard Variants for 7SR54		
7SR5420-2AA	1/2, 16 BI, 8 BO, 8 I Housing width 1/2 x 19" (size 8), housing height 4U 16 binary inputs 8 binary outputs (1 break, 2 changeover, 5 make) 8 current transformer inputs Communication: USB, RS485, 2 x Ethernet	
7SR5420-2AA	3/4, 16 BI, 8 BO, 8 I Housing width 3/4 x 19" (size 12), housing height 4U 16 binary inputs 8 binary outputs (1 break, 2 changeover, 5 make) 8 current transformer inputs Communication: USB, RS485, 2 x Ethernet	
7SR5420-3AA	1/2, 21 BI, 10 BO, 8 I Housing width 1/2 x 19" (size 8), housing height 4U 21 binary inputs 10 binary outputs (1 break, 2 changeover, 7 make) 8 current transformer inputs Communication: USB, RS485, 2 x Ethernet	
7SR5420-3AD	1/2, 21 BI, 13 BO (inc. 3 HSBO), 8 I, 3 AFD Housing width 1/2 x 19" (size 8), housing height 4U 21 binary inputs 13 binary outputs (1 break, 2 changeover, 10 make) 8 current transformer inputs Communication: USB, RS485, 2 x Ethernet	
7SR5420-3AD	3/4, 21 BI, 13 BO (inc. 3 HSBO), 8 I, 3 AFD Housing width 3/4 x 19" (size 12), housing height 4U 21 binary inputs 13 binary outputs (1 break, 2 changeover, 10 make) 8 current transformer inputs Communication: USB, RS485, 2 x Ethernet	
7SR5420-3AF	1/2, 21 BI, 10 BO, 8 I, 8 TSI Housing width 1/2 x 19" (size 8), housing height 4U 21 binary inputs 10 binary outputs (1 break, 2 changeover, 7 make) 8 current transformer inputs Communication: USB, RS485, 2 x Ethernet	
7SR5421-1AA	3/4, 12 BI, 8 BO, 8 I, 4 V Housing width 3/4 x 19" (size 12), housing height 4U 12 binary inputs 8 binary outputs (1 break, 2 changeover, 5 make) 8 current transformer inputs 4 voltage transformer inputs Communication: USB, RS485, 2 x Ethernet	

Devices and Application

Transformer Differential Protection – Reyrolle 7SR54

2.5

7SR5421-2AA	1/2, 17 BI, 10 BO, 8 I, 4 V Housing width 1/2 x 19" (size 8), housing height 4U 17 binary inputs 10 binary outputs (1 break, 2 changeover, 7 make) 8 current transformer inputs 4 voltage transformer inputs Communication: USB, RS485, 2 x Ethernet	
7SR5421-2AD	1/2, 17 BI, 13 BO (inc. 3 HSBO), 8 I, 4 V, 3 AFD Housing width 1/2 x 19" (size 8), housing height 4U 17 binary inputs 13 binary outputs (1 break, 2 changeover, 10 make) 8 current transformer inputs 4 voltage transformer inputs Communication: USB, RS485, 2 x Ethernet	
7SR5421-2AD	3/4, 17 BI, 13 BO (inc. 3 HSBO), 8 I, 4 V, 3 AFD Housing width 3/4 x 19" (size 12), housing height 4U 17 binary inputs 13 binary outputs (1 break, 2 changeover, 10 make) 8 current transformer inputs 4 voltage transformer inputs Communication: USB, RS485, 2 x Ethernet	
7SR5421-2AF	1/2, 17 BI, 10 BO, 8 I, 4 V, 8 TSI Housing width 1/2 x 19" (size 8), housing height 4U 17 binary inputs 10 binary outputs (1 break, 2 changeover, 7 make) 8 current transformer inputs 4 voltage transformer inputs Communication: USB, RS485, 2 x Ethernet	
7SR5421-3AA	3/4, 22 BI, 12 BO, 8 I, 4 V Housing width 3/4 x 19" (size 12), housing height 4U 22 binary inputs 12 binary outputs (1 break, 2 changeover, 9 make) 8 current transformer inputs 4 voltage transformer inputs Communication: USB, RS485, 2 x Ethernet	
7SR5421-3AD	3/4, 22 BI, 15 BO (inc. 3 HSBO), 8 I, 4 V, 3 AFD Housing width 3/4 x 19" (size 12), housing height 4U 22 binary inputs 15 binary outputs (1 break, 2 changeover, 12 make) 8 current transformer inputs 4 voltage transformer inputs Communication: USB, RS485, 2 x Ethernet	
7SR5421-3AF	3/4, 22 BI, 12 BO, 8 I, 4 V, 8 TSI Housing width 3/4 x 19" (size 12), housing height 4U 22 binary inputs 12 binary outputs (1 break, 2 changeover, 9 make) 8 current transformer inputs 4 voltage transformer inputs Communication: USB, RS485, 2 x Ethernet	

7SR5421-6AA	3/4, 37 BI, 18 BO, 8 I, 4 V	
	Housing width 3/4 x 19" (size 12), housing height 4U 37 binary inputs 18 binary outputs (1 break, 2 changeover, 15 make) 8 current transformer inputs 4 voltage transformer inputs Communication: USB, RS485, 2 x Ethernet	
7SR5421-6AD	3/4, 37 BI, 21 BO (inc. 3 HSBO), 8 I, 4 V, 3 AFD	
	Housing width 3/4 x 19" (size 12), housing height 4U 37 binary inputs 21 binary outputs (1 break, 2 changeover, 18 make) 8 current transformer inputs 4 voltage transformer inputs Communication: USB, RS485, 2 x Ethernet	
7SR5421-6AF	3/4, 37 BI, 18 BO, 8 I, 4 V, 8 TSI	
	Housing width 3/4 x 19" (size 12), housing height 4U 37 binary inputs 18 binary outputs (1 break, 2 changeover, 15 make) 8 current transformer inputs 4 voltage transformer inputs Communication: USB, RS485, 2 x Ethernet	
7SR5430-3AA	3/4, 24 BI, 10 BO, 12 I	
	Housing width 3/4 x 19" (size 12), housing height 4U 24 binary inputs 10 binary outputs (1 break, 2 changeover, 7 make) 12 current transformer inputs Communication: USB, RS485, 2 x Ethernet	
7SR5430-3AD	3/4, 24 BI, 13 BO (inc. 3 HSBO), 12 I, 3 AFD	
	Housing width 3/4 x 19" (size 12), housing height 4U 24 binary inputs 13 binary outputs (1 break, 2 changeover, 10 make) 12 current transformer inputs Communication: USB, RS485, 2 x Ethernet	
7SR5430-3AF	3/4, 24 BI, 10 BO, 12 I, 8 TSI	
	Housing width 3/4 x 19" (size 12), housing height 4U 24 binary inputs 10 binary outputs (1 break, 2 changeover, 7 make) 12 current transformer inputs Communication: USB, RS485, 2 x Ethernet	
7SR5431-3AA	3/4, 25 BI, 12 BO, 12 I, 4 V	
	Housing width 3/4 x 19" (size 12), housing height 4U 25 binary inputs 12 binary outputs (1 break, 2 changeover, 9 make) 12 current transformer inputs 4 voltage transformer inputs Communication: USB, RS485, 2 x Ethernet	

Devices and Application

Transformer Differential Protection – Reyrolle 7SR54

2.5

7SR5431-3AD	3/4, 25 BI, 15 BO (inc. 3 HSBO), 12 I, 4 V, 3 AFD Housing width 3/4 x 19" (size 12), housing height 4U 25 binary inputs 15 binary outputs (1 break, 2 changeover, 12 make) 12 current transformer inputs 4 voltage transformer inputs Communication: USB, RS485, 2 x Ethernet	
7SR5431-3AF	3/4, 25 BI, 12 BO, 12 I, 4 V, 8 TSI Housing width 3/4 x 19" (size 12), housing height 4U 25 binary inputs 12 binary outputs (1 break, 2 changeover, 9 make) 12 current transformer inputs 4 voltage transformer inputs Communication: USB, RS485, 2 x Ethernet	
7SR5431-5AA	3/4, 35 BI, 16 BO, 12 I, 4 V Housing width 3/4 x 19" (size 12), housing height 4U 35 binary inputs 16 binary outputs (1 break, 2 changeover, 13 make) 12 current transformer inputs 4 voltage transformer inputs Communication: USB, RS485, 2 x Ethernet	
7SR5431-5AD	3/4, 35 BI, 19 BO (inc. 3 HSBO), 12 I, 4 V, 3 AFD Housing width 3/4 x 19" (size 12), housing height 4U 35 binary inputs 19 binary outputs (1 break, 2 changeover, 16 make) 12 current transformer inputs 4 voltage transformer inputs Communication: USB, RS485, 2 x Ethernet	
7SR5431-5AF	3/4, 35 BI, 16 BO, 12 I, 4 V, 8 TSI Housing width 3/4 x 19" (size 12), housing height 4U 35 binary inputs 16 binary outputs (1 break, 2 changeover, 13 make) 12 current transformer inputs 4 voltage transformer inputs Communication: USB, RS485, 2 x Ethernet	

Table 2.5/2 Standard Variants for 7SR54

The technical data of the devices can be found in the hardware manual.

Description

The Reyrolle 5 is designed for the electricity networks of the future with enhanced communications and cyber security while maintaining a user-friendly interface and easy product management.

The Reyrolle 7SR57 motor protection devices include a wide range of protection functions and IEC 61850 Ethernet communications as standard. To further minimize the product variants the power supply and the binary inputs cover the full operating range with configurable binary input thresholds.

The large LCD, tactile pushbuttons and programmable LEDs provide a user-friendly product interface and the relay element is withdrawable for easy replacement.

Input and outputs	Current inputs – 4 or 8 Voltage inputs – 0 or 4 Binary inputs (max) – 29 Binary outputs (max) incl. healthy contact – 16 Arc flash detector inputs (AFD) – 0 or 3 High speed binary outputs (HSBO) – 0 or 3 Temperature sensor inputs (TSI) – 0, 8, or 16
Communication	Standard front USB port (for configuration using Reydisp Manager 2, a PC based software tool) rear RS485, 2 x RJ45 electrical ports or optional optical Ethernet connections
Housing	Size 6, 8, or 12 with withdrawable design
Display	Backlit 128 x 128 LCD with text and graphical display capabilities suitable for single line mimic diagrams

Benefits

- Compact design and low product life-cycle cost
- Reliable operation due to powerful, proven protection algorithms
- IEC 61850 Edition 1 & 2 with HSR, PRP and RSTP operation for increased availability
- Simple product ordering
- Combined 1 A and 5 A current transformer inputs
- 28 programmable tri-color LEDs for clear indications.
- User selectable languages: English, French, German, Portuguese, Spanish, Turkish
- Conformal coating ordering option

Functions

Standard Functionality

- 14 Locked rotor protection
- 37/37G Undercurrent protection – phase/earth
- 46BC Broken conductor detection
- 46PR Phase-rotation reversal
- 46UB Phase unbalance



[3C_7SR5_7SR57; 2, ...]

- 48 Starting-time supervision
- 49M Motor thermal overload protection
- 49TS Temperature sensor supervision ¹¹
- 50/50G/50N Instantaneous overcurrent/earth fault
- 50AFD Arc flash detection ¹²
- 50BCL Break capacity limit
- 50BF Circuit-breaker failure protection – 3-pole
- 51/51G/51N Time delayed overcurrent/earth fault
- 52 Circuit-breaker control
- 60CTS CT supervision
- 66 Number of starts
- 74CC/74TC Close-circuit and trip-circuit supervision
- 81B Backspin monitor
- 81HB2 Inrush current detection
- 86 Lockout
- 87GH Restricted earth fault protection – high-impedance

Additional Functionality – Devices with VT Inputs

- 27/27Vx Undervoltage protection
- 32 Power protection
- 47 Sequence overvoltage protection
- 55 Power factor
- 59/59Vx Overvoltage protection
- 59N Neutral voltage displacement
- 60VTS VT supervision
- 67/67G/67N Directional – phase/earth fault
- 81 Frequency protection – "f>" or "f<"
- 81B-V Backspin monitor – voltage reference
- 87M Motor differential protection

Monitoring Functions

- Primary, secondary, phase sequence, current and voltage
- Frequency, power, and energy

¹¹ An external interface unit is required where optional TSI module not fitted.

¹² Requires external components

Devices and Application

Motor Protection – Reyrolle 7SR57

- Fault data, event and waveform records
- Motor start data log

Applications

- Motor protection functions designed to protect during all motor starting and running sequences
- Thermal algorithm optimized to closely match the thermal characteristics of motors
- Thermal monitoring via plant temperature sensors supported

Communication

- IEC 60870-5-103, Modbus TCP, DNP3 TCP
Modbus RTU, DNP3, IEC 61850, Modbus Client for connection to external RTD box

Application Templates

2.6

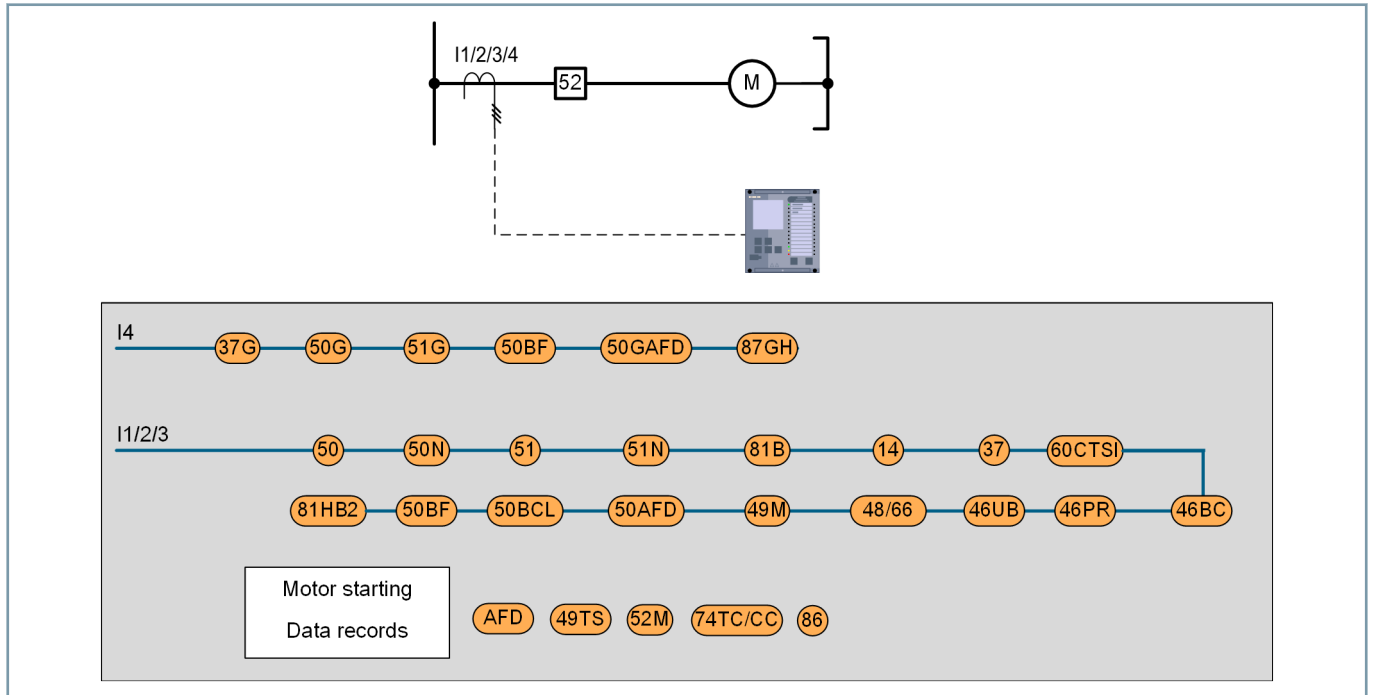

[dw_7SR5_7SR5710_FunctionDiagram_4_en_US]

Figure 2.6/1 7SR5710 Motor Protection Function Diagram

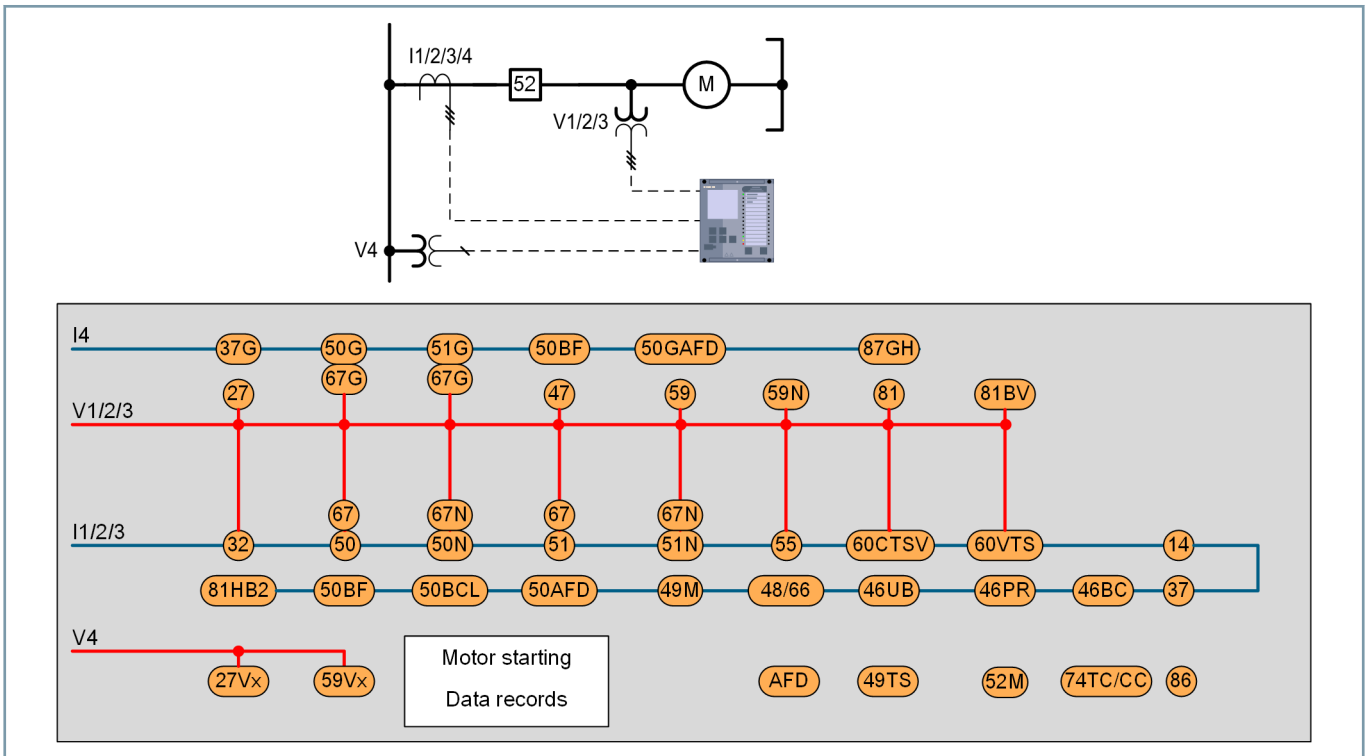

[dw_7SR5_7SR5711_functiondiagram, 4, en_US]

Figure 2.6/2 7SR5711 Motor Protection Function Diagram

Devices and Application

Motor Protection – Reyrolle 7SR57

2.6

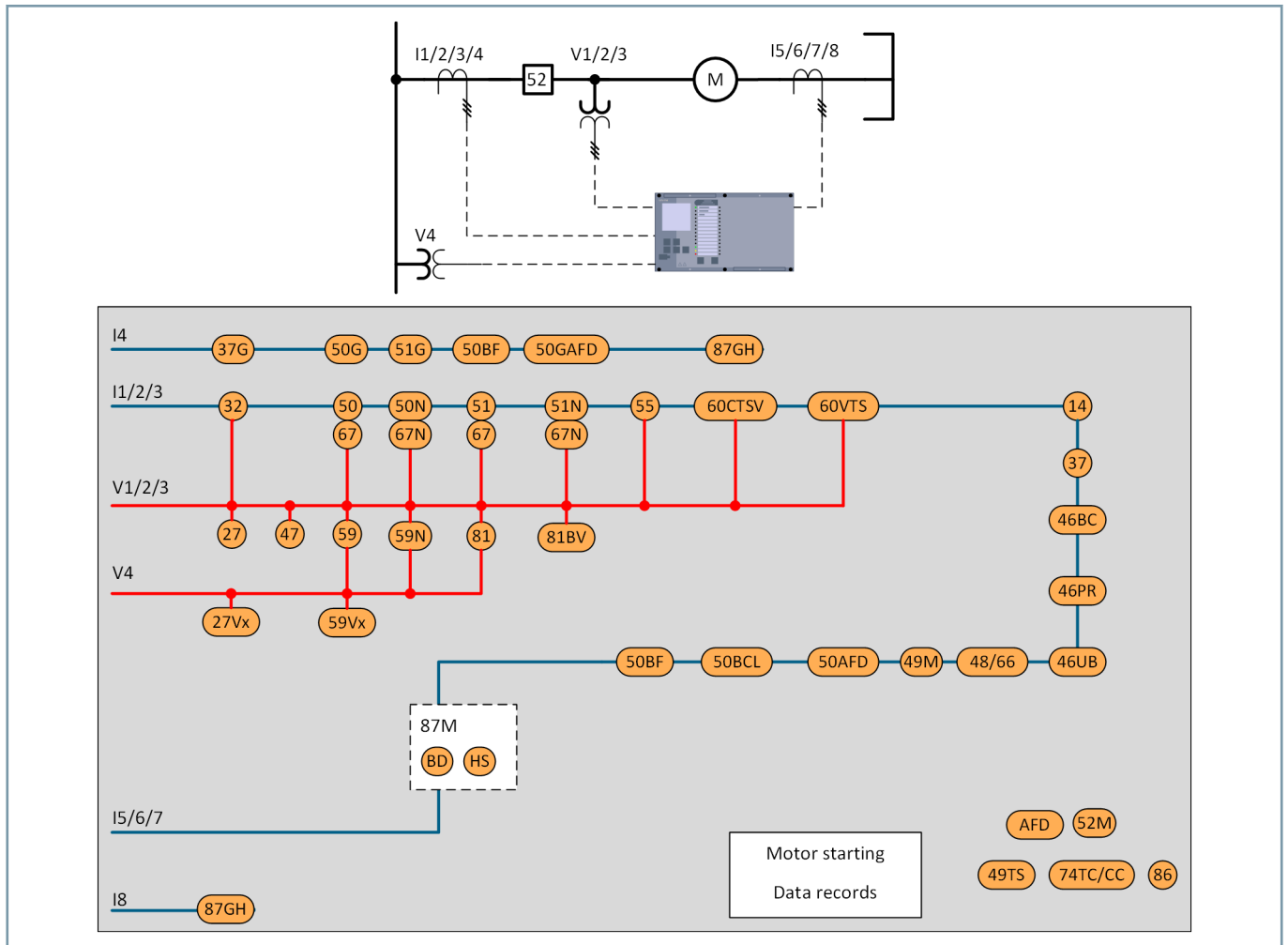

[dw_7SR5_7SR5721_functiondiagram_5_en_US]

Figure 2.6/3 7SR5721 Motor Protection Function Diagram

Functions, Application Templates

ANSI	Functions	7SR5710	7SR5711	7SR5721
14	Locked rotor protection	■	■	■
27	Undervoltage protection – 3-phase	–	■	■
27Vx	Undervoltage protection – Vx	–	■	■
32	Power protection	–	■	■
37	Undercurrent protection – phase	■	■	■
37G	Undercurrent earth fault – measured	■	■	■
46BC	Broken conductor detection	■	■	■
46PR	Phase-rotation reversal	■	■	■
46UB	Phase unbalance	■	■	■
47	Sequence overvoltage protection	–	■	■
48	Starting-time supervision	■	■	■
49M	Motor thermal overload protection	■	■	■
49TS	Temperature sensor supervision ¹³	■	■	■
50	Instantaneous overcurrent – phase	■	■	■
50AFD	Arc flash detection ¹⁴	■	■	■
50BCL	Break capacity limit	■	■	■
50BF	Circuit-breaker failure protection – 3-pole	■	■	■
50G	Instantaneous earth fault – measured	■	■	■
50N	Instantaneous earth fault – calculated	■	■	■
51	Time-delayed overcurrent – phase	■	■	■
51G	Time delayed earth fault – measured	■	■	■
51N	Time-delayed earth fault – calculated	■	■	■
52	Circuit-breaker control	■	■	■
55	Power factor	–	■	■
59	Overvoltage protection – 3-phase	–	■	■
59N	Neutral voltage displacement	–	■	■
59Vx	Overvoltage protection – Vx	–	■	■
60CTS-I	CT supervision – current reference	■	–	–
60CTS-V	CT supervision – voltage reference	–	■	■
60VTS	VT supervision	–	■	■
66	Number of starts	■	■	■
67	Directional overcurrent – phase	–	■	■
67G	Directional earth fault – measured	–	■	■
67N	Directional earth fault – calculated	–	■	■
74CC	Close-circuit supervision	■	■	■
74TC	Trip-circuit supervision	■	■	■
81	Frequency protection – "f>" or "f<"	–	■	■
81B	Backspin monitor	■	–	–
81B-V	Backspin monitor – voltage reference	–	■	■
81HB2	Inrush current detection	■	■	■
86	Lockout	■	■	■
87GH	Restricted earth fault protection – high-impedance	■	■	■
87M	Motor differential protection	–	–	■
	Measured values	■	■	■
	Switching-statistic counters	■	■	■
	Circuit-breaker wear monitoring	■	■	■
	Logic editor	■	■	■
	External trip initiation	■	■	■

¹³ An external interface unit is required where optional TSI module not fitted.

¹⁴ Requires external components

Devices and Application

Motor Protection – Reyrolle 7SR57

2.6

ANSI	Functions	7SR5710	7SR5711	7SR5721
	Control	■	■	■
	Fault recording of analog and binary signals	■	■	■
	Sequence of events recorder	5000	5000	5000
	Motor operating records	■	■	■
	Security log	2048	2048	2048
	Monitoring and supervision	■	■	■
	Setting groups	4	4	4
	Changeover of setting group	■	■	■
	Binary inputs (max)	23	29	27
	Arc flash detector inputs (AFD)	0 or 3	0 or 3	0 or 3
	Temperature sensor inputs (TSI)	0 or 8	0, 8, or 16	0, 8, or 16
	Binary outputs (max) incl. healthy contact	12	16	14
	High speed binary outputs (HSBO)	0 or 3	0 or 3	0 or 3
	Current inputs	4	4	8
	Voltage inputs	0	4	4
	Size	6, 8, or 12	6, 8, or 12	8 or 12
	LCD resolution	128x128		
	Push buttons	7	7	7
	LEDs	28	28	28
	Power supply unit rated voltages	DC 24 to 250 V AC 100 to 230 V		
	Front user interface	■	■	■
	User selectable languages: English, French, German, Portuguese, Spanish, Turkish	■	■	■
	IEC 60870-5-103	■	■	■
	IEC 61850	■	■	■
	Modbus RTU	■	■	■
	Modbus TCP	■	■	■
	SNMP v3	■	■	■
	DNP3	■	■	■
	DNP3 TCP	■	■	■
	Time synchronization: Binary input, DNP3, Modbus RTU, DNP TCP, Modbus TCP, SNTP, IEEE 1588 PTP	■	■	■







Table 2.6/1 Reyrolle 7SR57 – Functions and Application Templates



NOTE

■ - Basic







Standard Variants

Standard Variants for 7SR57		
7SR5710-1AA	3/8, 8 BI, 6 BO, 4 I Housing width 3/8 x 19" (size 6), housing height 4U 8 binary inputs 6 binary outputs (1 break, 2 changeover, 3 make) 4 current transformer inputs Communication: USB, RS485, 2 x Ethernet	
7SR5710-1AD	3/8, 8 BI, 9 BO (inc. 3 HSBO), 4 I, 3 AFD Housing width 3/8 x 19" (size 6), housing height 4U 8 binary inputs 9 binary outputs (1 break, 2 changeover, 6 make) 4 current transformer inputs Communication: USB, RS485, 2 x Ethernet	
7SR5710-1AF	3/8, 8 BI, 6 BO, 4 I, 8 TSI Housing width 3/8 x 19" (size 6), housing height 4U 8 binary inputs 6 binary outputs (1 break, 2 changeover, 3 make) 4 current transformer inputs Communication: USB, RS485, 2 x Ethernet	
7SR5710-2AA	3/8, 13 BI, 8 BO, 4 I Housing width 3/8 x 19" (size 6), housing height 4U 13 binary inputs 8 binary outputs (1 break, 2 changeover, 5 make) 4 current transformer inputs Communication: USB, RS485, 2 x Ethernet	
7SR5710-2AD	3/8, 13 BI, 11 BO (inc. 3 HSBO), 4 I, 3 AFD Housing width 3/8 x 19" (size 6), housing height 4U 13 binary inputs 11 binary outputs (1 break, 2 changeover, 8 make) 4 current transformer inputs Communication: USB, RS485, 2 x Ethernet	
7SR5710-2AF	3/8, 13 BI, 8 BO, 4 I, 8 TSI Housing width 3/8 x 19" (size 6), housing height 4U 13 binary inputs 8 binary outputs (1 break, 2 changeover, 5 make) 4 current transformer inputs Communication: USB, RS485, 2 x Ethernet	
7SR5710-3AA	1/2, 18 BI, 10 BO, 4 I Housing width 1/2 x 19" (size 8), housing height 4U 18 binary inputs 10 binary outputs (1 break, 2 changeover, 7 make) 4 current transformer inputs Communication: USB, RS485, 2 x Ethernet	

Devices and Application

Motor Protection – Reyrolle 7SR57

2.6

7SR5710-3AD	1/2, 18 BI, 13 BO (inc. 3 HSBO), 4 I, 3 AFD Housing width 1/2 x 19" (size 8), housing height 4U 18 binary inputs 13 binary outputs (1 break, 2 changeover, 10 make) 4 current transformer inputs Communication: USB, RS485, 2 x Ethernet	
7SR5710-3AF	1/2, 18 BI, 10 BO, 4 I, 8 TSI Housing width 1/2 x 19" (size 8), housing height 4U 18 binary inputs 10 binary outputs (1 break, 2 changeover, 7 make) 4 current transformer inputs Communication: USB, RS485, 2 x Ethernet	
7SR5710-4AA	1/2, 23 BI, 12 BO, 4 I Housing width 1/2 x 19" (size 8), housing height 4U 23 binary inputs 12 binary outputs (1 break, 2 changeover, 9 make) 4 current transformer inputs Communication: USB, RS485, 2 x Ethernet	
7SR5710-4AD	1/2, 23 BI, 15 BO (inc. 3 HSBO), 4 I, 3 AFD Housing width 1/2 x 19" (size 8), housing height 4U 23 binary inputs 15 binary outputs (1 break, 2 changeover, 12 make) 4 current transformer inputs Communication: USB, RS485, 2 x Ethernet	
7SR5710-4AF	1/2, 23 BI, 12 BO, 4 I, 8 TSI Housing width 1/2 x 19" (size 8), housing height 4U 23 binary inputs 12 binary outputs (1 break, 2 changeover, 9 make) 4 current transformer inputs Communication: USB, RS485, 2 x Ethernet	
7SR5711-1AA	3/8, 9 BI, 8 BO, 4 I, 4 V Housing width 3/8 x 19" (size 6), housing height 4U 9 binary inputs 8 binary outputs (1 break, 2 changeover, 5 make) 4 current transformer inputs 4 voltage transformer inputs Communication: USB, RS485, 2 x Ethernet	
7SR5711-1AD	3/8, 9 BI, 11 BO (inc. 3 HSBO), 4 I, 4 V, 3 AFD Housing width 3/8 x 19" (size 6), housing height 4U 9 binary inputs 11 binary outputs (1 break, 2 changeover, 8 make) 4 current transformer inputs 4 voltage transformer inputs Communication: USB, RS485, 2 x Ethernet	

7SR5711-1AF	3/8, 9 BI, 8 BO, 4 I, 4 V, 8 TSI Housing width 3/8 x 19" (size 6), housing height 4U 9 binary inputs 8 binary outputs (1 break, 2 changeover, 5 make) 4 current transformer inputs 4 voltage transformer inputs Communication: USB, RS485, 2 x Ethernet	
7SR5711-3AA	1/2, 19 BI, 12 BO, 4 I, 4 V Housing width 1/2 x 19" (size 8), housing height 4U 19 binary inputs 12 binary outputs (1 break, 2 changeover, 9 make) 4 current transformer inputs 4 voltage transformer inputs Communication: USB, RS485, 2 x Ethernet	
7SR5711-3AA	3/4, 19 BI, 12 BO, 4 I, 4 V Housing width 3/4 x 19" (size 12), housing height 4U 19 binary inputs 12 binary outputs (1 break, 2 changeover, 9 make) 4 current transformer inputs 4 voltage transformer inputs Communication: USB, RS485, 2 x Ethernet	
7SR5711-3AD	1/2, 19 BI, 15 BO (inc. 3 HSBO), 4 I, 4 V, 3 AFD Housing width 1/2 x 19" (size 8), housing height 4U 19 binary inputs 15 binary outputs (1 break, 2 changeover, 12 make) 4 current transformer inputs 4 voltage transformer inputs Communication: USB, RS485, 2 x Ethernet	
7SR5711-3AD	3/4, 19 BI, 15 BO (inc. 3 HSBO), 4 I, 4 V, 3 AFD Housing width 3/4 x 19" (size 12), housing height 4U 19 binary inputs 15 binary outputs (1 break, 2 changeover, 12 make) 4 current transformer inputs 4 voltage transformer inputs Communication: USB, RS485, 2 x Ethernet	
7SR5711-3AF	1/2, 19 BI, 12 BO, 4 I, 4 V, 8 TSI Housing width 1/2 x 19" (size 8), housing height 4U 19 binary inputs 12 binary outputs (1 break, 2 changeover, 9 make) 4 current transformer inputs 4 voltage transformer inputs Communication: USB, RS485, 2 x Ethernet	
7SR5711-5DD	3/4, 29 BI, 19 BO (inc. 3 HSBO), 4 I, 4 V, 3 AFD, 16 TSI Housing width 3/4 x 19" (size 12), housing height 4U 29 binary inputs 19 binary outputs (1 break, 2 changeover, 16 make) 4 current transformer inputs 4 voltage transformer inputs Communication: USB, RS485, 2 x Ethernet	

Devices and Application

Motor Protection – Reyrolle 7SR57

7SR5721-2AA	<p>1/2, 17 BI, 10 BO, 8 I, 4 V</p> <p>Housing width 1/2 x 19" (size 8), housing height 4U</p> <p>17 binary inputs</p> <p>10 binary outputs (1 break, 2 changeover, 7 make)</p> <p>8 current transformer inputs</p> <p>4 voltage transformer inputs</p> <p>Communication: USB, RS485, 2 x Ethernet</p>	
7SR5721-2AD	<p>1/2, 17 BI, 13 BO (inc. 3 HSBO), 8 I, 4 V, 3 AFD</p> <p>Housing width 1/2 x 19" (size 8), housing height 4U</p> <p>17 binary inputs</p> <p>13 binary outputs (1 break, 2 changeover, 10 make)</p> <p>8 current transformer inputs</p> <p>4 voltage transformer inputs</p> <p>Communication: USB, RS485, 2 x Ethernet</p>	
7SR5721-2AF	<p>1/2, 17 BI, 10 BO, 8 I, 4 V, 8 TSI</p> <p>Housing width 1/2 x 19" (size 8), housing height 4U</p> <p>17 binary inputs</p> <p>10 binary outputs (1 break, 2 changeover, 7 make)</p> <p>8 current transformer inputs</p> <p>4 voltage transformer inputs</p> <p>Communication: USB, RS485, 2 x Ethernet</p>	
7SR5721-4DD	<p>3/4, 27 BI, 17 BO (inc. 3 HSBO), 8 I, 4 V, 3 AFD, 16 TSI</p> <p>Housing width 3/4 x 19" (size 12), housing height 4U</p> <p>27 binary inputs</p> <p>17 binary outputs (1 break, 2 changeover, 14 make)</p> <p>8 current transformer inputs</p> <p>4 voltage transformer inputs</p> <p>Communication: USB, RS485, 2 x Ethernet</p>	

Table 2.6/2 Standard Variants for 7SR57

The technical data of the devices can be found in the hardware manual.

2.6

**NOTE**

For devices that have more than one current input group the source of the operating current for each element can be configured.

14 Locked Rotor Protection

Each function element has a single definite time overcurrent characteristic with settings for pickup level and Definite Time Lag (DTL) delays.

Operation can be controlled from motor stopped or running conditions.

21FL Fault Locator

The relay provides a basic single-end type fault locator which is able to estimate the fault position using analogue information measured by the relay at one end of the protected circuit during the short duration of the fault.

21LB Load Blinder

Load blinders block directional overcurrent tripping during periods of high reverse load currents that can occur due to increased contribution from distributed generation in the network. The blinder is operated during user defined load conditions. The application of appropriate settings can be derived by analysis of the data logger stored records.

24 Overexcitation Protection

Excess flux density causes stray flux to flow into transformer components external to the core, causing eddy currents and over-heating. Damage can be caused to transformer insulation.

In DTL mode 2 elements are provided each having an independent definite time lag (DTL) characteristic.

In 'User Defined' mode a user defined pick-up/time characteristic is implemented. Operation occurs where the measured Voltage : Frequency ratio is above setting for a time in excess of the time delayed operation.

25 Synchrocheck – Synchronization Function

Voltage, phase and frequency differences on opposing sides of the open circuit-breaker are checked before manual close and autoreclose circuit-breaker operations to ensure that the circuit-breaker is not closed in abnormal system conditions.

27 Undervoltage Protection – 3-Phase

Each element has settings for voltage pickup, drop-off (hysteresis) and definite time lag (DTL) operate delay. Operation occurs where the voltage falls below setting for the duration of the DTL setting.

27Vx Undervoltage Protection – Vx

This single phase element has settings as per 27 undervoltage protection – 3 phase.

32 Power Protection

Directional power elements are used to detect reverse load flow or loss of load.

Each element can be set to measure real, apparent or reactive power. Settings for pickup level and definite time lag (DTL) delayed operation are available for each element.

37 Undercurrent Protection

Undercurrent elements are used to detect loss of load or current flow. In some transformer applications an undercurrent check is used as a primary plant switching inter-lock/check.

Each element has settings for pickup level and definite time lag (DTL) delay – operating where the current falls below setting for a time exceeding the DTL setting.

46 Negative-Sequence Overcurrent Protection

NPS current elements can be used to detect unbalances on the system or remote earth faults when a delta-star transformer is in circuit.

2 elements, one DTL and one IDMT, with user settings for pickup level and delays, will operate if NPS current exceeds setting and delay.

46BC Broken Conductor Detection

Elements are used to detect transformer OLTC mechanism failures or broken phase conductors.

Each phase unbalance element has settings for pickup level and DTL delay – operating where 1 or 2 of the measured currents fall below the pick-up setting for a time exceeding the DTL setting.

46PR Phase-rotation reversal

Detects rotation of the current vectors and is used to avoid reverse rotation of the motor.

46UB Phase Unbalance

Unbalance current has a significant heating effect on the motor.

2 phase unbalance measurement modes are available. Either NPS current or the difference between maximum and minimum phase currents can be used as a measurement of the unbalance level. Inverse or definite time operation can be selected.

47 Sequence Overvoltage Protection

Phase sequence voltage elements operate where the selected sequence voltage (V1, V2 or V0) exceeds setting for a period in excess of the operate time.

Each element has settings for pickup level and definite time lag (DTL) delays. Operation occurs where the voltage exceeds setting for the duration of the DTL setting.

48 Starting-Time Supervision

Motor start up time is monitored by this function.

An output is raised if the start time exceeds the setting.

49 Thermal Overload Protection

The thermal algorithm calculates the circuit thermal state from the measured currents. 2 elements provide different heating time constants for natural and forced cooling operation.

Outputs are available for thermal overload and thermal capacity.

49M Motor Thermal Overload Protection

The enhanced thermal algorithm provides compliance with IEC 60255-8 (Thermal Electrical Relays).

The operating curves take into account the effects of present loading, prior loading, and unbalanced currents on the motor operating temperature.

System

Protection

A user definable thermal curve is selectable to allow matching of the relay thermal characteristic to all motor and cooling system types.

“Starting” and “cooling” constants modify the thermal characteristic during motor run-up and stopped conditions.

49TS Temperature Sensor Supervision

Resistance temperature detectors (RTDs) and thermistors can be monitored when the optional temperature sensor input (TSI) module is specified.

Resistance temperature detectors (RTDs) can also be connected via an optional external Temperature Monitoring Interface. Up to 12 Pt100 sensors can be monitored. The interface is connected to the RS485 serial communications port.

50 Instantaneous Overcurrent – Phase

The 3 phase currents are measured to provide instantaneous overcurrent protection.

Settings for pickup current operation are available for each independent time (50) element.

An operate time delay can also be applied.

50AFD Arc Flash Detection

All 7SR5 devices can be used with the 7XG31 ReyArc range of arc flash detection devices.

Optionally, 7SR5 devices can be ordered with 3 x light sensing AFD inputs which can be connected to P1X series arc sensors.

Arc detection is employed for the fast clearance of arcing faults on busbars, within metal clad switchgear and associated cable boxes. The arc is detected using an optical sensor and the signal input to the relay which also monitors the load current on the system.

50BCL Breaking-Capacity Limit

Operation of the tripping outputs can be blocked if the measured current exceeds this setting. This function is used to prevent the interrupting capacity of the primary switching device being exceeded.

50BF Circuit-Breaker Failure Protection – 3 Pole

Where a CB fails to open and current continues to flow then an alternative means of interrupting the current flow must be implemented. A CB fail output can be used to re-trip the CB (e.g. second trip coil) or to trip adjacent CBs. 2 DTLs are provided to facilitate 2 stage operation if required.

The circuit-breaker fail function can be initiated from an internal trip signal or from a binary input.

Line currents are monitored following trip initiation and outputs issued if any current is still flowing after elapse of a user selectable time delay.

50G Instantaneous Earth Fault – Measured

Earth current is directly measured from an independent CT or the residual connection of the 3 line CTs.

Settings for pickup current operation are available for each independent time (50G) element.

50GHS High Speed Earth Fault – Measured

High speed measured earth fault element for faster clearance of high current faults.

50GI Intermittent Earth Fault

For identification of intermittent, self clearing earth faults by counting fault occurrences and integration of fault current pulse duration for use on compensated networks and cable systems.

50GS Instantaneous Sensitive Earth Fault – Measured

Earth current is directly measured from an independent CT or the residual connection of the 3 line CTs.

Settings for pickup current and time delayed operation are available for each independent time (50G) element.

50HS High Speed Overcurrent – Phase

High speed overcurrent element for faster clearance of high current faults.

50N Instantaneous Earth Fault – Calculated

Earth current is calculated from the sum of the 3 phase CT inputs.

Settings for pickup current operation are available for each independent time (50N) element.

50SOTF Switch onto Fault

SOTF functionality provides high speed tripping if a fault is still present on the feeder after the reclosure of the circuit-breaker (Close-on-to-Fault) or if earthing clamps are left connected after maintenance.

51 Time-Delayed Overcurrent – Phase

The 3 phase currents are measured to provide time delayed overcurrent protection.

Settings for time delayed operation are available for each dependent time (51) element.

Dependent time elements (51) also have selectable IEC/ANSI operate and reset characteristics.

Minimum operating time and additional Follower DTL can also be configured for increased flexibility.

51CL Cold Load Overcurrent – Phase

If a circuit-breaker is closed onto load that has not been powered for a prolonged period a higher than normal load-current can flow until the load stabilizes. To allow optimum setting levels to be applied during this period the cold load pickup feature applies alternative overcurrent settings for a limited time.

The overcurrent function reverts to normal in service settings when either the circuit-breaker has been closed for a defined period, or the current has fallen below a set level for a defined period.

51G Time-Delayed Earth Fault – Measured

Earth current is directly measured from an independent CT or the residual connection of the 3 line CTs.

Settings for time-delayed operation are available for each dependent time (51G) element.

Dependent time elements (51G) also have selectable IEC/ANSI operate and reset characteristics.

51GS Time-Delayed Sensitive Earth Fault – Measured

Earth current is directly measured from an independent CT or the residual connection of the 3 line CTs.

Settings for time-delayed operation are available for each dependent time (51G) element.

Dependent time elements (51G) also have selectable IEC/ANSI operate and reset characteristics.

51N Time-Delayed Earth Fault – Calculated

Earth current is calculated from the sum of the 3 phase CT inputs.

Settings for time-delayed operation are available for each dependent time (51N) element.

Dependent time elements (51N) also have selectable IEC/ANSI operate and reset characteristics.

51V Voltage-Dependent Overcurrent – Phase

In 'Restrained' mode this element increases the sensitivity of the overcurrent protection proportionally with the decrease in the system voltage.

In 'Control' mode the element modifies the time multiplier applied to the 51/67 phase fault elements when the system voltage falls below setting.

55 Power Factor

This feature is used to monitor the system power factor, it is used for system monitoring and/or in conjunction with load flow optimization schemes.

Each element has independent settings for pickup level and definite time lag (DTL) delayed operation.

59 Overvoltage Protection – 3 Phase

Each element has settings for voltage pickup, drop-off (hysteresis) and definite time lag (DTL) operate delay. Operation occurs where the voltage exceeds setting for the duration of the DTL setting.

59N Neutral Voltage Displacement

2 elements, 1 DTL and 1 IDMTL, have user settings for pickup level and delays. These will operate if the neutral voltage exceeds the setting for duration of delay. Neutral overvoltage can be used to detect earth faults in high-impedance earthed or isolated systems.

60CTS-I CT Supervision – Current Reference

Open or short circuited CTs will not allow correct fault detection or stability measurement. Open circuited CTs may cause damaging over-voltages.

Protections can be blocked or an alarm raised, each element has settings for pickup level and DTL delay – operating where 1 or 2 of the line currents fall below the pick-up setting for a time exceeding the DTL setting.

60CTS-V CT Supervision – Voltage Reference

Each element has settings for V_{nps} and I_{nps} pickup levels and DTL delay – operating where V_{nps} is below setting and I_{nps} is above setting for a time exceeding the DTL setting. The CT supervision function typically provides an alarm output.

60VTS VT Supervision

The VT supervision uses a combination of negative phase sequence voltage and negative phase sequence current to detect a VT fuse failure. This condition may be alarmed or used to inhibit voltage dependent functions. Element has user operate and delay settings.

66 Number of Starts

The feature provides settings to control both the number of times a motor can be started within a specified time period and the minimum time between starts. Motor starting can be inhibited when this limit is reached.

67 Directional Overcurrent – Phase

Each element can be user set for forward, reverse, or non-directional operation.

Directional overcurrent elements are polarized from 3 phase quadrature voltage.

67G Directional Earth Fault – Measured

Each element can be user set for forward, reverse, or non-directional operation.

On 7SR5121 models with 2 measured earth current inputs, the source of the 67G current can be selected. Overcurrent elements using that measured current input can provide the directional option.

Earth fault elements are polarized using a residual voltage reference V_0 .

67GI Directional Intermittent Earth Fault

Settings are provided for directional polarizing which are independent of the other earth fault elements.

On 7SR5121 models with 2 measured earth current inputs, the source of the 67GI current can be selected. Overcurrent elements using that measured current input can provide the directional option.

Elements are polarized using the residual voltage reference V_0 . Each element can be set for forward, reverse, or non-directional operation.

67GS Directional Sensitive Earth Fault – Measured

Each element can be user set for forward, reverse, or non-directional operation.

On 7SR5121 models with 2 measured earth current inputs, the source of the 67GS current can be selected. Overcurrent elements using that measured current input can provide the directional option.

Sensitive earth fault elements are polarized using a residual voltage reference V_0 .

67N Directional Earth Fault – Calculated

Each element can be user set for forward, reverse, or non-directional operation.

Where a suitable V_0 reference is not available then calculated earth fault element (N) can also operate in 'NPS Voltage Polarisng' mode.

System

Protection

74CC Close-Circuit Supervision

The close-circuit supervision can be monitored via binary inputs connected in basic, intermediate or comprehensive schemes. Close-circuit failure raises an HMI alarm and output(s).

74TC Trip-Circuit Supervision

The trip-circuit supervision can be monitored via binary inputs connected in basic, intermediate or comprehensive schemes. Trip-circuit failure raises an HMI alarm and output(s).

78VS Voltage Vector Shift

The voltage vectors of each phase are monitored and an output initiated when an abrupt phase shift above setting is detected simultaneously in all 3 phases. This indicates a sudden change in the system generation/load balance.

The function is applied to detect 'islanding' or loss of connection between a generator and the main utility supply.

79 Automatic Reclosing

Flexible, independent automatic reclosing sequences for phase and earth fault protection operations are provided.

Up to 5 trips + 4 reclose operations can be attempted.

Automatic reclosing sequences can be user set to any configuration of 'Instantaneous' or 'Delayed' protection trips, with independent reclose (Dead) times. Instantaneous/Delayed elements are user defined from the dependent and independent time elements available.

Limits can be set for the number of 'Delayed' trips to lockout and 'High set' trips to lockout.

The automatic reclosing feature can also be initiated by external protection devices e.g. from a separate line protection relay. External trips can be blocked to allowing the implementation of grading by overcurrent protections.

81 Frequency Protection – " $f>$ " or " $f<$ "

Frequency protection is used to initiate load shedding or generator start up. Over-frequency detectors can be used for generation shedding or within a load restoration permissible logic scheme.

Each element has settings for frequency pickup, drop-off (hysteresis) and definite time lag (DTL) operate delay. Operation occurs where the frequency exceeds setting for the duration of the DTL setting.

81B Backspin Monitor

To inhibit attempted restarting of the motor until after the rotor has completely stopped backspin protection is applied. Starting is inhibited until the 81B time delay has elapsed.

81HB2 Inrush Current Detection

A high content of second harmonic current is an indication of transformer energization inrush current.

Harmonic detectors are provided for both line and differential currents.

Where the measured second harmonic level is above the setting operation of the transformer differential and the overcurrent protection is blocked by 81HB2.

81HB5 Overfluxing Detection – 5th Harmonic

A high content of fifth harmonic current can indicate transformer over-fluxing conditions.

Harmonic detectors measure the fifth harmonic level in the transformer differential current and when above setting operation of the biased differential element (87T-BD) protection can be blocked.

81R Frequency Protection – " df/dt "

Each element has settings for pickup level and definite time lag (DTL) delay. Operates when the df/dt gradient exceeds setting for duration of delay.

The function is typically applied in load shedding schemes or to detect 'islanding' or loss of connection between a generator and the main utility supply.

86 Lockout

Output relays can be configured to self reset, pulsed or hand reset operation.

Output relays can be used to directly trip the circuit-breaker. The operate 'break' duty of output relays is limited so the circuit-breaker trip coil must be open circuited by a suitably rated contact, typically a circuit-breaker auxiliary switch.

87GH Restricted Earth-Fault Protection – High-Impedance

Restricted earth fault protection provides high sensitivity and high operating speed for internal earth faults as it is associated with only one transformer winding and so does not require harmonic stabilization.

To implement the high impedance restricted earth fault protection scheme the secondary windings of the line and neutral CTs are wired in parallel and connected to the measured earth current input. Class PX CTs with identical ratios must be used.

An external series stabilizing resistor and a voltage limiting (non-linear) resistor are required to complete the scheme.

87M Motor Differential Protection

87M-BD provides biased low impedance differential protection for phase and earth faults. 87M-HS provides fast protection for high internal fault currents e.g. terminal faults.

87NL Restricted Earth-Fault Protection – Low-Impedance

The line and neutral CTs provide inputs to a low-impedance restricted earth fault scheme.

For 7SR5121 models with 2 earth current inputs, CT4 is used.

A percentage biased algorithm is implemented.

Internal current multipliers allow the use of line and neutral CTs with different ratios.

87T-BD Transformer Differential Protection – Biased

The differential characteristic incorporates an initial setting and two bias stages – the first stage for steady state errors i.e. tap position and CT ratios the second stage for transient errors i.e. CT saturation.

87T-HS Transformer Differential Protection – Highset

Unrestrained differential elements provide a fast protection for high internal fault currents e.g. terminal faults.

Programmable User Logic

The user can map binary inputs and protection operated outputs to function inhibits, logic inputs, LEDs and/or binary outputs. In addition to graphical user logic that is configured in the PC tool the user can map binary inputs and protection operated outputs to function inhibits, logic inputs, LEDs, and/or binary outputs using simple text based equations that can be viewed and edited at the device fascia. The user can also enter up to 16 equations defining scheme logic using standard functions e.g. timers, AND/OR gates, inverters and counters. Each protection element output can be used for alarm & indication and/or tripping.

Circuit-Breaker Maintenance

Up to 3 sets of circuit-breaker operations counters are provided. For each set:

- The maintenance counters record the overall number of operations.
- The delta counter records the number of operations since the last reset.
- The I²t summation counter provides a measure of the contact wear indicating the total energy interrupted by the circuit-breaker contacts.

Each counter has a user set target operations count which, when reached, can be mapped to raise alarms/binary outputs. These counters assist with maintenance scheduling.

Plant Maintenance

2 circuit-breaker operations counters are provided. The maintenance counters record the overall number of operations and the delta counter the number of operations since the last reset.

An I²t summation counter provides a measure of the contact wear indicating the total energy interrupted by the circuit-breaker contacts.

Each counter has a user set target operations count which, when reached, can be mapped to raise alarms/binary outputs. These counters assist with maintenance scheduling.

Plant Control

Plant control can be provided from the relay fascia or via the data comms channel(s).

The fascia mimic screen can be configured to provide a visual representation of the primary plant configuration and operate state.

System

Monitoring

Can include

Instruments and Meters

- Current:
 - Primary phases and earth
 - Secondary phases and earth
 - Relay operate and restraint
 - Phase sequence (PPS, NPS, ZPS)
 - Differential operate and restraint
- Voltage:
 - Primary
 - Secondary
 - Phase sequence (PPS, NPS, ZPS)
- Frequency & fluxing
- Power
- Energy
- Fault location
- Temperature (when temperature sensors are connected)
- Binary input/output and virtual I/O status
- Time and date
- Fault data records
- Event records (selectable events viewable on fascia)
- Waveform records
- Motor start records

Plant Data

- CB trip counters
- CB trip current counters
- CB I²t summation (wear) counters
- Plant parameters
- Data logging (demand history)

Energy Metering

The imported and exported energy values are stored. Data is available for both active (Wh) and reactive (VARh) energy quantities.

Fault Data Records

The last 100 fault records are displayed on the HMI, with time and date of trip, measured quantities and type of fault.

Waveform Records

The waveform recorder stores analogue data for all inputs, protection function states, binary inputs/outputs and LEDs.

A waveform record can be triggered from protection function, binary input or via data communications.

The latest 20 waveform records can be stored. Waveform records are of 1, 2, 5 or 10 s duration. The ratio of pre-fault to post-fault storage is user selectable.

Waveforms are available for all relay functions and analogue inputs – the displayed waveforms are user selectable.

Motor Start Records (7SR57 Devices)

The records for motor starts include the following information:

- Start date
- Start time
- Number of starts
- Motor start duration
- Thermal capacity used for last start
- Total thermal capacity used
- Maximum starting current
- Minimum start voltage (requires voltage inputs)

Event Records

Up to 5000 events are stored and time tagged to 1 ms resolution.

Selectable events can be displayed on the relay fascia or in the event recorder readout.

Data Log

The average values of current, voltage, power, and power factor (where applicable) are recorded at a user selectable interval e.g. every 15 min covers the preceding 7 days.

This stored data log facilitates load flow analysis. In conjunction with data communications and control this information can be used to optimize network power flows, for example in dynamic grids.

Real-Time Clock

The time and date can be set and are maintained while the relay is de-energized by a back up storage capacitor. The time can be synchronized from a binary input pulse, the serial or data communication port using a selected protocol or the Ethernet interface using DNP3 TCP, Modbus TCP, SNTP, or IEEE 1588 PTP. The real-time clock supports selectable main and backup clock signal source from binary input, serial port, or Ethernet interface as well as dual SNTP clock support.

Communications

Reyrolle 7SR5 devices are equipped with high performance integrated communication interfaces as standard. All devices include:

- Front USB port for local connection configuration
- Rear RS485 serial communication for SCADA interface

In addition 2 rear Ethernet interface ports are provided as standard. Ordering options provide the selection for: The Ethernet port types are specified when ordered as

- 2 x RJ45 Electrical Ethernet interfaces/connections **OR**
- 2 x duplex LC 1300-nm optical Ethernet interfaces/connections

The electrical Ethernet interface can be configured with or without an integrated switch. The maximum electrically recommended distance via CAT 5/CAT 6 patch cables is 20 m.

The optical Ethernet interface can be configured with or without an integrated switch. The maximum optically permitted distance via 50/125 µm or 62.5/125 µm multimode optical fibers is 2 km.

Serial Protocols (RS485 Port)

The RS485 port is intended for connection to a system interface and can be selected to **OFF** or to use any one of the serial protocols, IEC 60870-5-103, Modbus RTU or DNP3. The implementation is compatible with existing Reyrolle 7SR solutions. The serial protocol mapping information can be viewed and configured in Reydisp Manager, this enables adaptation to existing solutions and the interchangeability of devices without changes in the systems control.

IEC 60870-5-103

In addition to indications, measured values, and fault records, metered values, and customer-specific defined indications of systems control are also available in protocol extensions. Control commands for switching devices can also be transmitted via the protocol.

DNP3

DNP3 information about a device and the fault records of the device can be routed and transmitted using the DNP3 protocol. Switching commands can be executed in control direction.

Modbus RTU

Modbus can be used to transmit messages (single-point and double-point indications), measured values, and metered values to 1 master. In command direction, switching of switching objects is possible via the protocol.

Ethernet Protocols

Ethernet modules are used for Ethernet-based protocol applications, for example, IEC 61850, Modbus TCP, time synchronization via SNTP, and network management via SNMP etc. Several applications can run in parallel, unused applications can be switched off for security reasons. The rear Ethernet interfaces are not configured with an IP address by default and must be configured prior to use.

IEC 61850-8-1 Client-Server Communication is always provided on the 7SR5 Ethernet interface and it supports 6 client-server

associations with reporting function and GOOSE messages. Messages, measured values, and fault records can be read from an IEC 61850 client and the time of the device can be set via an SNTP server. Measured and metered values can be transmitted via the client-server communication in static and dynamic reports to a maximum of 6 clients (substation controllers). Dynamic reports are created and read by the client without configuring the parameters of the device. The static reports are created via the IEC 61850 system configurator and are permanently saved in the device as indication lists. Fault records can also be retrieved in COMTRADE format. Extensive control functions are available from the client, such as for the safe switching of a circuit breaker.

IEC 61850-8-1 GOOSE

GOOSE has been established as a worldwide standard for the exchange of messages between devices. The exchange itself occurs via high-performance IP network connections or Ethernet network connections. GOOSE messages can be used to exchange time-critical information that must be transmitted in a few milliseconds e.g. to replace protection signals between contacts and binary inputs. GOOSE applications are generated in the system configurator for this purpose.

Modbus TCP

Modbus TCP communication protocol utilises the electrical or optical Ethernet interface and can be used alongside the IEC 61850. Only Modbus TCP or DNP3 TCP can be used or configured at any time. Modbus TCP uses TCP packets for data transmission and is similar in operation to the Modbus RTU protocol. Modbus TCP can be used to transmit messages (single-point and double-point indications), measured values, metered values to 1 or 2 (redundant) masters. In the command direction, control operation of switching objects is possible via the protocol. Time synchronization can take place via the Modbus TCP protocol but should not be used when the SNTP time synchronizing is used.

Time synchronization can take place via the Modbus TCP protocol but should be disabled when the SNTP or IEEE 1588 PTP time synchronizing is used.

Further Ethernet-based Protocols and Services in addition to the actual protocol application, can be run in parallel on an Ethernet interface.

DNP3 TCP

DNP3 TCP communication protocol utilizes the electrical or optical ethernet interface and can be used alongside the IEC 61850. Only Modbus TCP or DNP3 TCP can be used or configured at any time.

The device reports event data in one of 3 class buffers, Class 1,2, or 3. Class 0 is supported as the current state condition. Where applicable the event data class can be modified in the Reydisp Manager 2 configuration file. Up to 2 masters can also be configured for unsolicited events.

Time synchronization can take place via the DNP3 TCP protocol but should be disabled when the SNTP or IEEE 1588 PTP time synchronizing is used.

Redundancy

Ethernet redundancy is supported on both the electrical and optical Ethernet allowing the building of redundant ring structures. They are independent of the substation automation protocol or the selected additional services.

With an integrated switch, electrical or optical rings with a maximum of 40 devices can be established using RSTP (Rapid Spanning Tree Protocol).

Seamless Redundancy with a reduced time for the reconfiguration of communication networks in the event of interruptions is supported with:

- PRP = Parallel Redundancy Protocol
- HSR = High Availability Seamless Redundancy

Time Synchronization via SNTP

Time Synchronization with SNTP Protocol is supported. The device can poll the absolute time from 1 or 2 time servers via an SNTP server. In redundant operation, both servers are read and the time of the 1st server is used for setting the device clock. If this server fails, the time is synchronized by the 2nd server.

IEEE 1588 Precision Time Protocol

Time synchronization by this protocol is supported in Line mode, RSTP, PRP, and HSR modes. **Ordinary Clock Slave Only** is provided, Domain Address 0, for all modes. IEC 61850-9-3:2016 profile is supported.

Network Monitoring via SNMP

The device can be integrated in network monitoring or power management systems via the SNMP protocol V3. SNMPV3 supports security features with authentication and privacy features. Monitoring variables, for example the state of the Ethernet interfaces, their data throughput etc. can be made known to the monitoring system via MIB (Management Information Base) files. No values can be changed in the device via SNMP. It serves exclusively as a diagnosis interface.

Cyber Security

With the increasing integration of bay devices in Ethernet-based communication networks, communication must be secured against internal disturbances and attacks from outside. Standards and directives contain requirements for the secure operation of devices in a critical communications infrastructure environment, and must be addressed by both manufacturers and operators.

By default only the front USB is enabled in the device to allow local connection. The rear Ethernet ports are not configured by default in the device and can be enabled and configured with Reydisp Manager.

Secure authentication takes place between the device and the communication partner (Reydisp Manager or web interface). This prevents an unauthorized program accessing the devices and reading or writing data there. The use of the transmission protocol secured by Datagram Transport Layer Security (DTLS) or Hypertext Transfer Protocol Secure (HTTPS) ensures the integrity and confidentiality of the transmitted data.

To ensure the Integrity of firmware and configuration of the 7SR5 device, files are digitally signed. In this way, corruption

from outside by viruses or trojans, for example by manipulated firmware files, is reliably prevented.

The 7SR5 device provides user authentication using a connection password and maintenance password.

The user has read and write access to the device only after the connection has been established by entering the predefined password.

The maintenance password is configured to restrict access for firmware upgrades, security log access and resetting of the connection password.

The passwords conform to the cybersecurity requirements for assigning passwords defined in NERC CIP. Passwords must have between 8 and 30 characters and must include upper-case and lower-case letters, digits, and special characters.

Operational security (safety) by means of confirmation ID for local access to the control operations and parameter changes from the fascia is also provided. These confirmation IDs can be configured by the user in Reydisp Manager and may be different for different fields of application. After entering the confirmation ID's the user has access until timed out.

Logging of events relevant to cybersecurity, such as login attempts or device restarts, are recorded and optionally transmitted to a central server via the standardized Syslog UDP protocol. The device-internal log entries are secured to prevent deletion and protected against unauthorised access with the Security ID for fascia access and the Maintenance Password for browser access.

Reydisp Manager 2

Reydisp Manager 2 (RM2) is a PC based engineering tool used for the setting and configuration of all Reyrolle 5 devices. Available to download free of charge from our web site this easy to use software ensures an efficient work flow.

A connection can be made to the relay via the high speed USB port or over an Ethernet network.

RM2 provides a modern interface allowing the user to apply and interrogate settings, create logic, retrieve event records, disturbance records and waveform records and project management of multiple devices.

For system configuration engineering of IEC 61850 projects an IEC 61850 system configuration tool will be required. Either the Siemens IEC 61850 System Configurator, as used by DIGSI, or a 3rd party IEC 61850 system configurator tool.

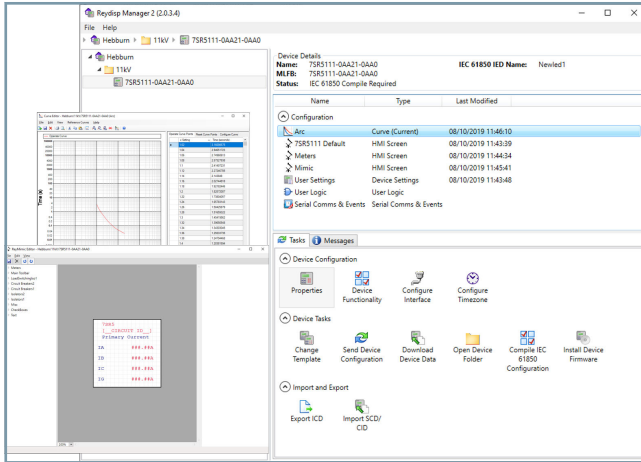





Figure 3.4/1 Typical Reydisp Manager 2 screenshot

Overview of Functions

- Protection setting parameterization both offline and online
- Device configuration
- Viewing of device instrumentation
- Logic editing
- Creation of user curves
- Serial protocol point editing
- HMI screen design and configuration
- Real time indications on all records allowing direct correlation between all relay records e.g. between waveform and event records
- Indication of all element operate states
- User triggering of protection, control and supervision functions from Reydisp
- Relay BI/BO matrix display
- Reports can be produced and exported
- Comtrade files
- Communications Editor
- Curve Editor
- Mimic Creator
 - Mimic Control: Primary plant can be controlled by the mimic interface
 - Mimic Display: The mimic can display primary plant positions/status

System

Hardware Construction

	Waste Electrical and Electronic Equipment Directive (WEEE)
	Guideline for the Eurasian Market
	Mandatory Conformity Mark for Electronics and Electrotechnical Products in Morocco
	South Korea KC Certification for Electrical and Electronic Products
	United Kingdom (UK) conformity-assessed marking
	USB port to connect to other devices e.g. laptop
	Electrostatic Sensitive Devices warning

Function LED's

28-user programmable tri-colour LEDs are provided, each can be configured to illuminate red, green or yellow allowing for indication of the associated function's state.

An LED label can be inserted behind the transparent hinged cover on the relay fascia.

The relay settings include a menu allowing the user to input further explanatory text for LED functionality. This is displayed in the LCD.

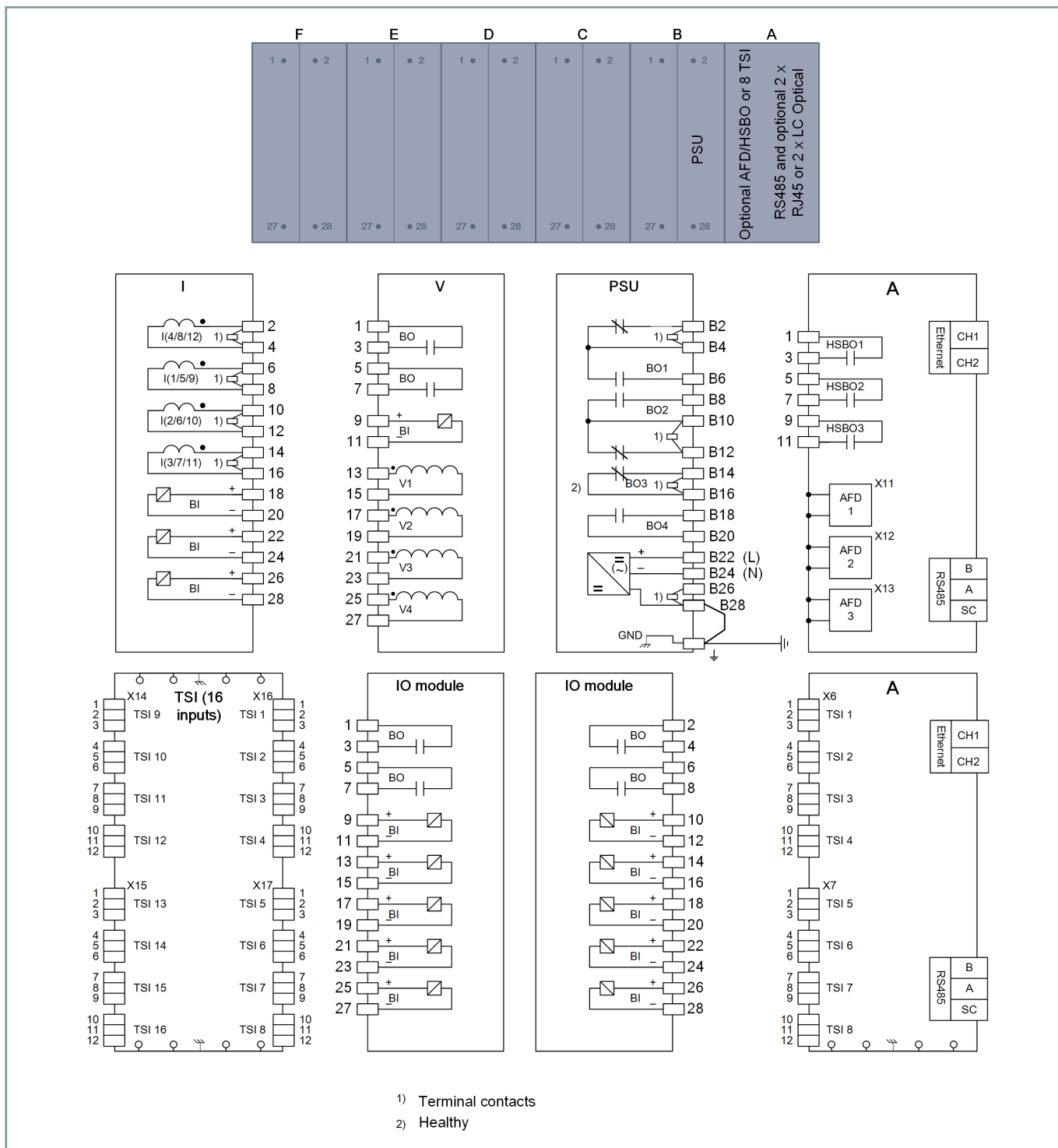

[dw_7SR5_terminals and modules, 6_en_US]

Figure 3.5/5 Rear View: Arrangement of Terminals and Modules

System

Hardware Construction – Terminals and Modules

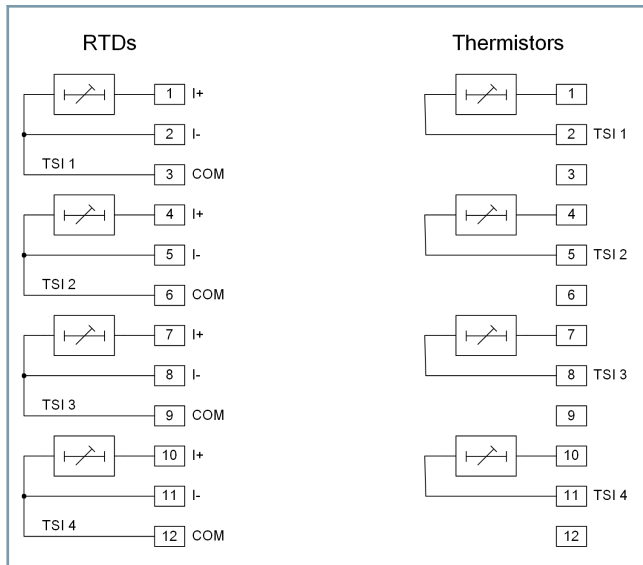

[dw_7SR5_RTD_thermistor_connections, 2, en_US]

Figure 3.5/6 RTD or Thermistor Connections (Shown for Temperature Sensor Inputs (TSI) 1 to 4)

Screened cable is recommended for use with the optional temperature inputs. There are 4 earth screw terminals available on the 8 TSI devices and 8 earth screw terminals available on the 16 TSI devices provided on the rear of the relay for cable screens.

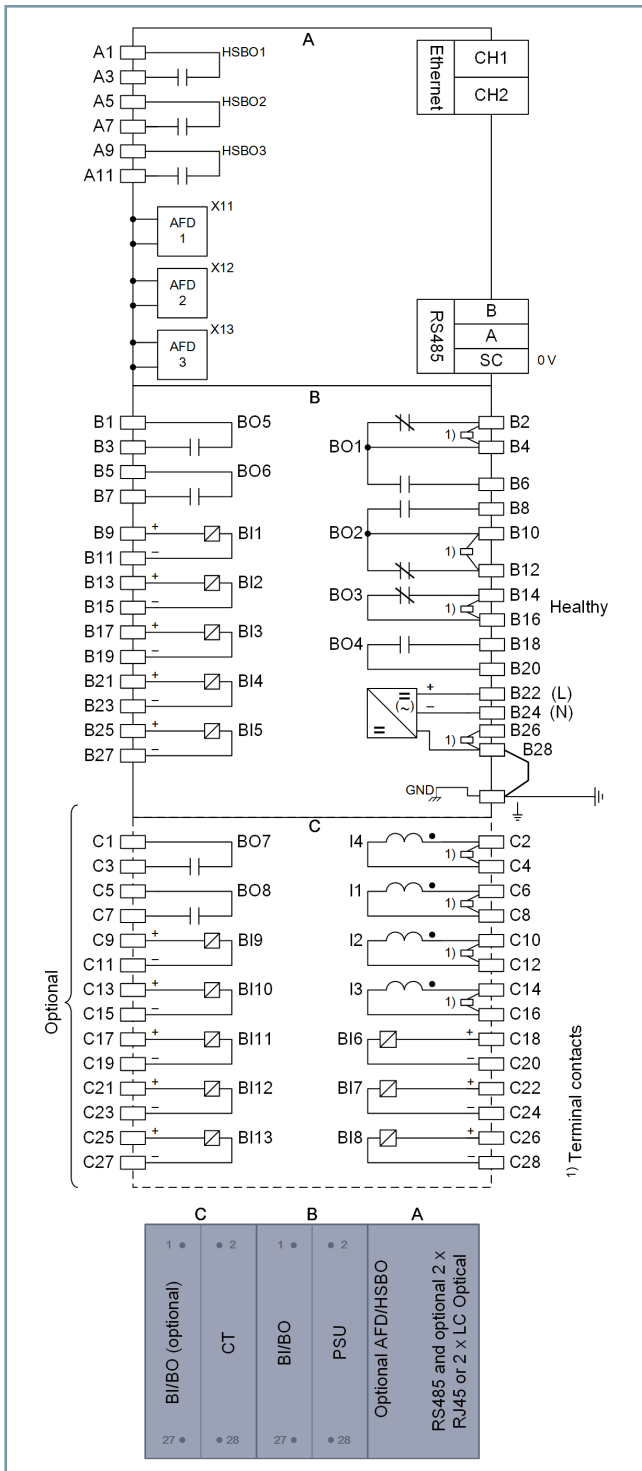

[HW_7SR5_overcurrent_wiring_diagram_4_en_US]

Figure 4.1/1 7SR5110 Overcurrent Relay Wiring Diagram

- AFD Arc flash detector input
- BI Binary input
- BO Binary output relay
- COM Data communications
- GND Ground/earth

HSBO High speed binary output

I Current transformer connection

PSU Power supply unit

Module 'A' is shown with optional AFD/HSBO fitted.

The case earth stud should be solidly earthed to the panel earth. Terminal B28 (power supply unit) should be connected to the case earth stud. A minimum wire size of 2.5 mm² is recommended.

Terminal contacts internal to the relay case assembly close when the relay element is withdrawn from the case.

Hardware Configurations: The wiring diagram shows a size 6 case. Where the size 8 or 12 case is used, additional BI/BO modules can be specified at extra cost – see ordering information sheet.

Technical Documentation

Connection Diagrams

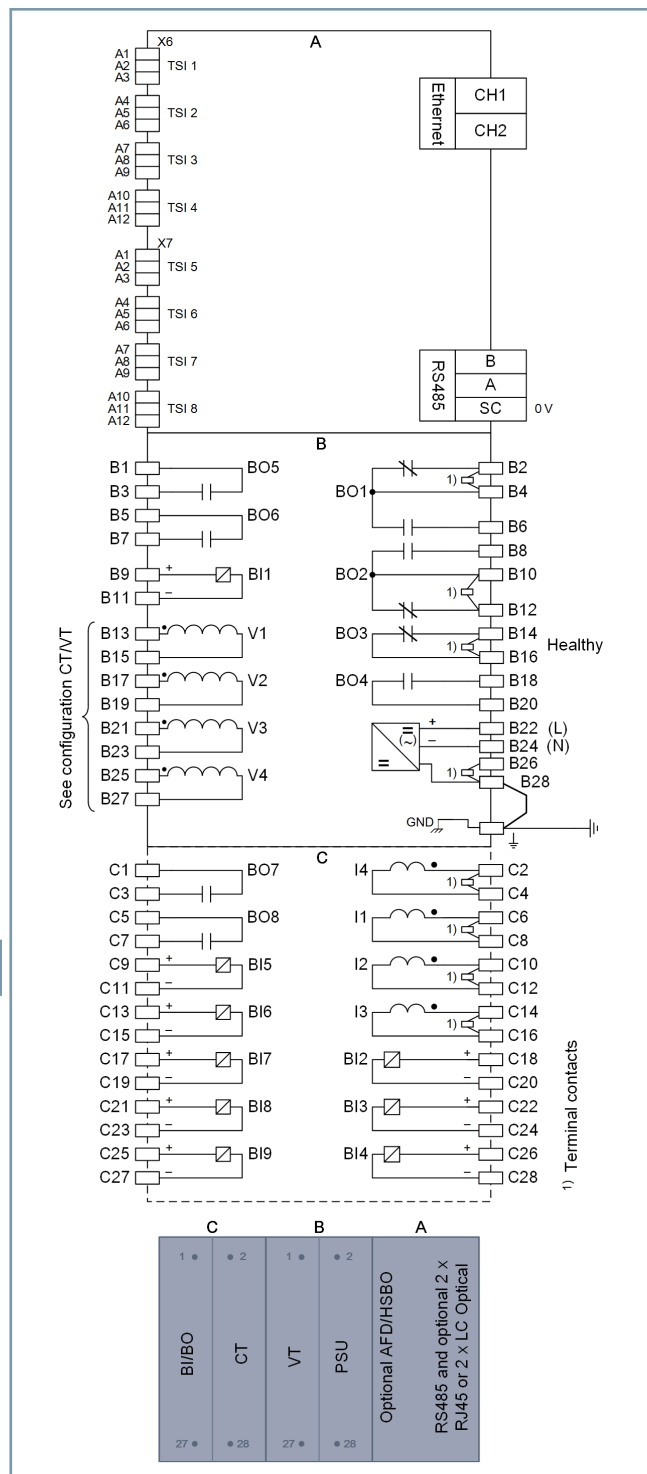

Figure 4.1/2 7SR5111 Directional Overcurrent Relay Wiring Diagram in TSI Inputs

- AFD Arc flash detector input
- BI Binary input
- BO Binary output relay
- COM Data communications
- GND Ground/earth

- HSBO High speed binary output
- I Current transformer connection
- PSU Power supply unit
- V Voltage transformer connection

Module 'A' is shown with optional TSI fitted.

The case earth stud should be solidly earthed to the panel earth. Terminal B28 (power supply unit) should be connected to the case earth stud. A minimum wire size of 2.5 mm² is recommended.

Terminal contacts internal to the relay case assembly close when the relay element is withdrawn from the case.

Hardware Configurations: The wiring diagram shows a size 6 case. Where the size 8 or 12 case is used, additional BI/BO modules can be specified at extra cost – see ordering information sheet.

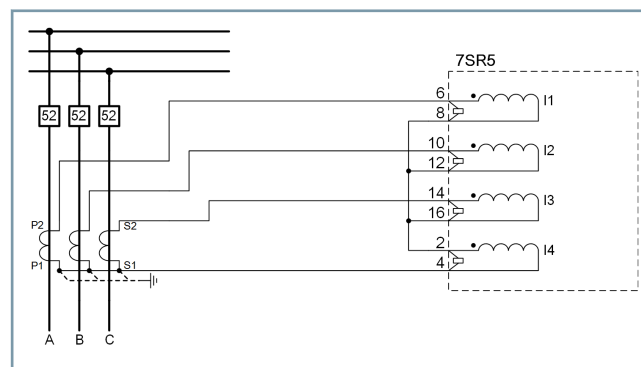

[dw_7SR5_ct-connection_diagram_01_2_en_US]

Figure 4.1/3 CT Connections: 3 Phase and Earth Current Measurement using 'Holmgreen' Connected CTs

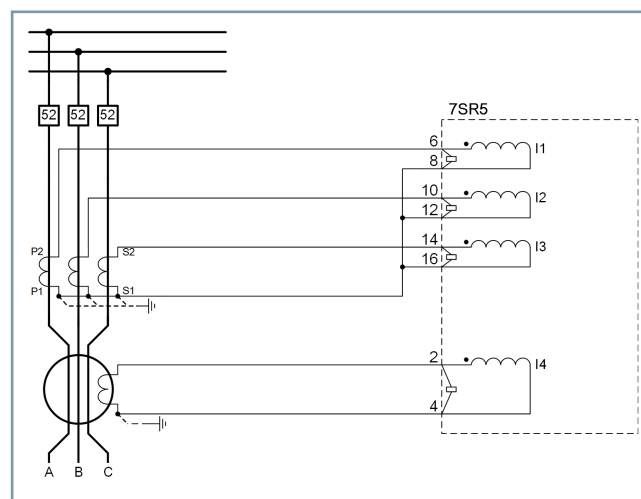

[dw_7SR5_ct-connection_diagram_02_3_en_US]

Figure 4.1/4 CT Connections: 3 Phase Current Measurement. Earth Current Measurement using Ring Core CT

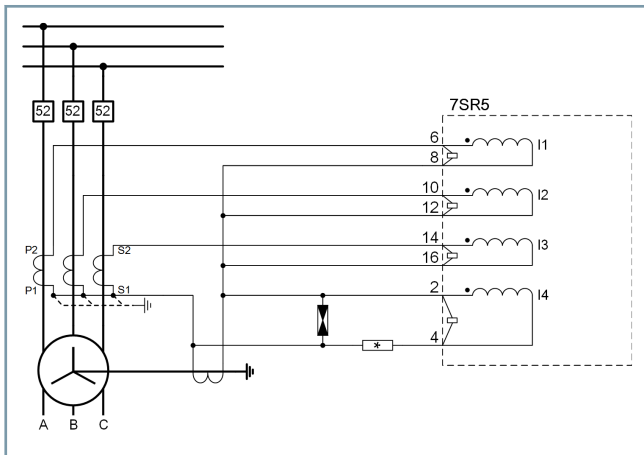

[dw_7SR5_ct-connection_diagram_03_2_en_US]

Figure 4.1/5 CT Connections: 3 Phase Current Measurement. High Impedance Restricted Earth Fault Protection

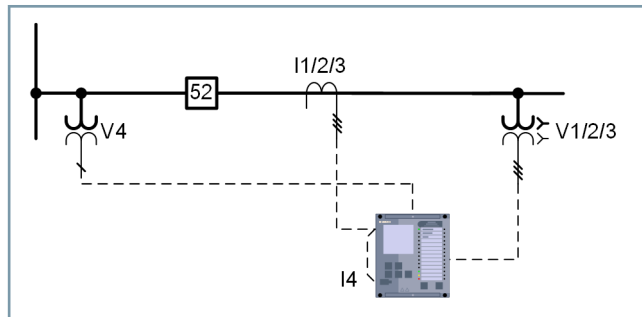

[dw_7SR5_ct-vt-connection_diagram_2_en_US]

Figure 4.1/9 Typical 4 CT, 4 VT Device Overall CT/VT Arrangement

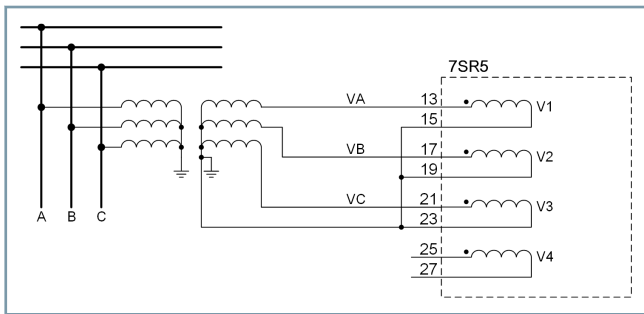

[dw_7SR5_vt-connection_diagram_01_3_en_US]

Figure 4.1/6 Configuration CTs/VTs > VT 1/2/3 Config = Van, Vbn, Vcn

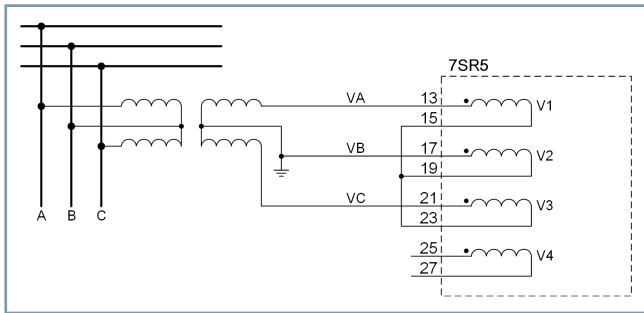

[dw_7SR5_vt-connection_diagram_02_2_en_US]

Figure 4.1/7 Configuration CTs/VTs > VT 1/2/3 Config = Va, Vb, Vc

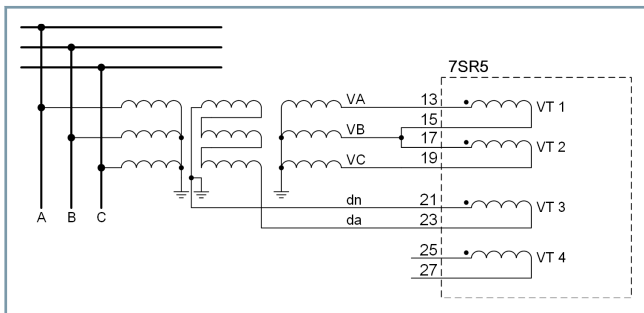

[dw_7SR5_vt-connection_diagram_03_2_en_US]

Figure 4.1/8 Configuration CTs/VTs > VT 1/2/3 Config = Vab, Vbc, 3V0

Technical Documentation

Connection Diagrams

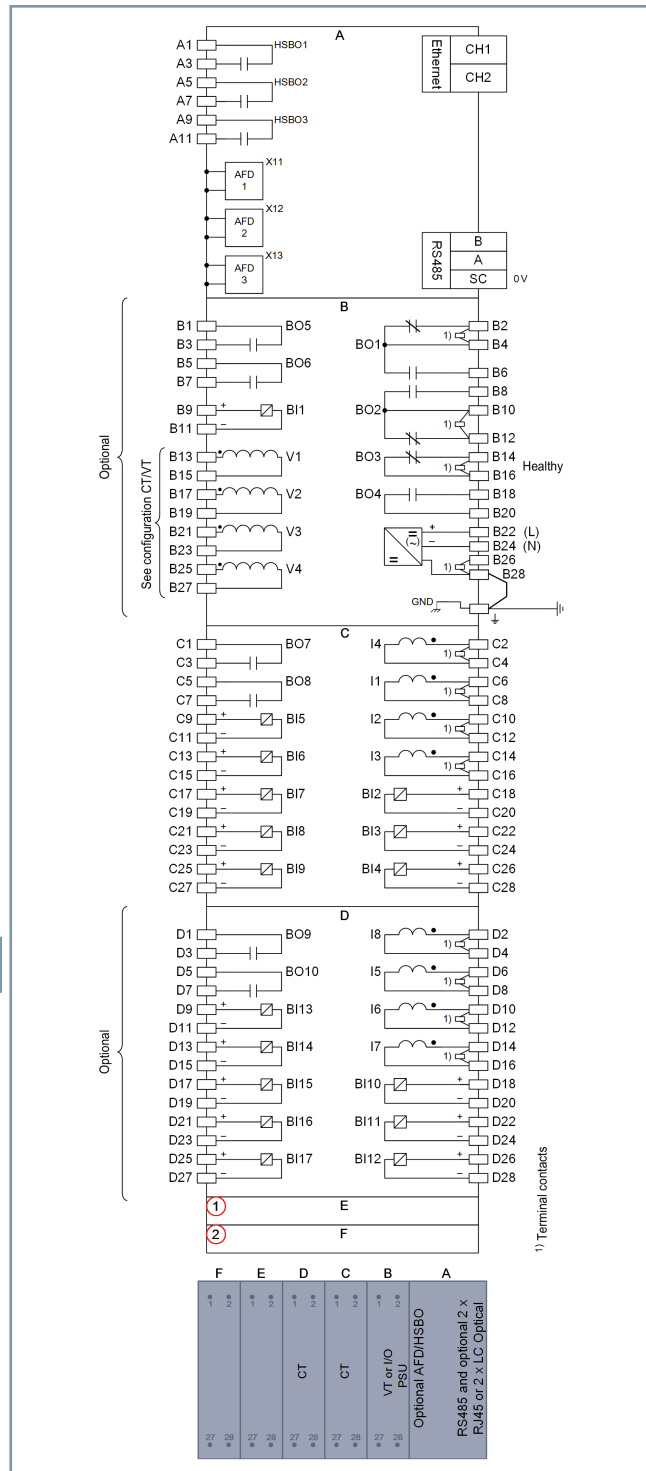

Terminal contacts internal to the relay case assembly close when the relay element is withdrawn from the case.

Hardware Configurations: The wiring diagram shows a size 8 case. Where the size 12 case is used, additional BI/BO modules can be specified at extra cost – see ordering information sheet.

4.1

[HW_7SR5_transformer_wiring_diagram_8_en_US]

Figure 4.1/10 7SR5421 Transformer Relay Wiring Diagram

Module 'A' is shown with optional AFD/HSBO fitted.

The case earth stud should be solidly earthed to the panel earth. Terminal B28 (power supply unit) should be connected to the case earth stud. A minimum wire size of 2.5 mm² is recommended.

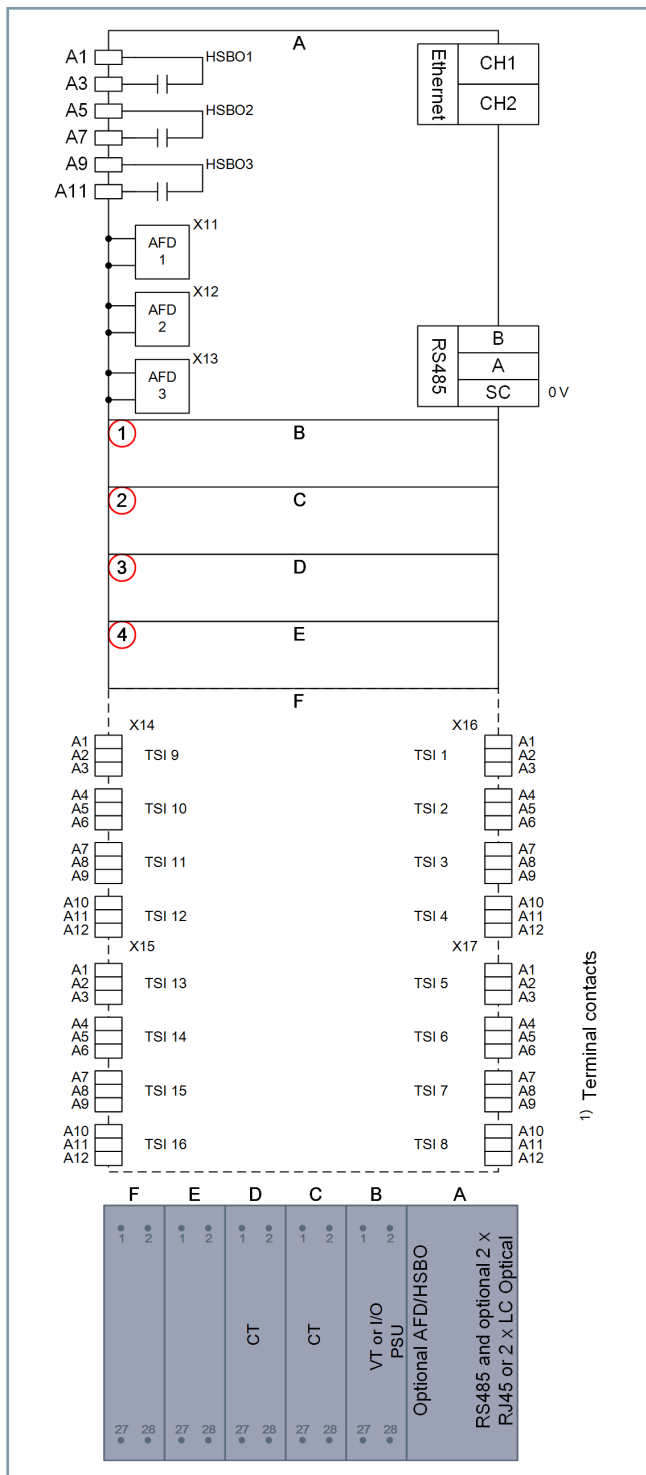

[HW_7SR5_motor_7SR5711_2_en_US]

Figure 4.1/11 7SR5711 Motor Relay Wiring Diagram

- 1 Dependent on device MLFB
 - 2 Dependent on device MLFB
 - 3 Dependent on device MLFB
 - 4 Dependent on device MLFB
- AFD Arc flash detector input

- BI Binary input
- BO Binary output relay
- COM Data communications
- GND Ground/earth
- HSBO High speed binary output
- I Current transformer connection
- PSU Power supply unit
- V Voltage transformer connection

Module 'A' is shown with optional AFD/HSBO fitted.

Module 'F' is shown with optional TSI module fitted.

The case earth stud should be solidly earthed to the panel earth. Terminal B28 (power supply unit) should be connected to the case earth stud. A minimum wire size of 2.5 mm² is recommended.

Terminal contacts internal to the relay case assembly close when the relay element is withdrawn from the case.

Hardware Configurations: The wiring diagram shows a size 12 case for a 2-winding transformer protection relay. Additional BI/BO modules can be specified at extra cost – see ordering information sheet.

Technical Documentation

Dimension drawings

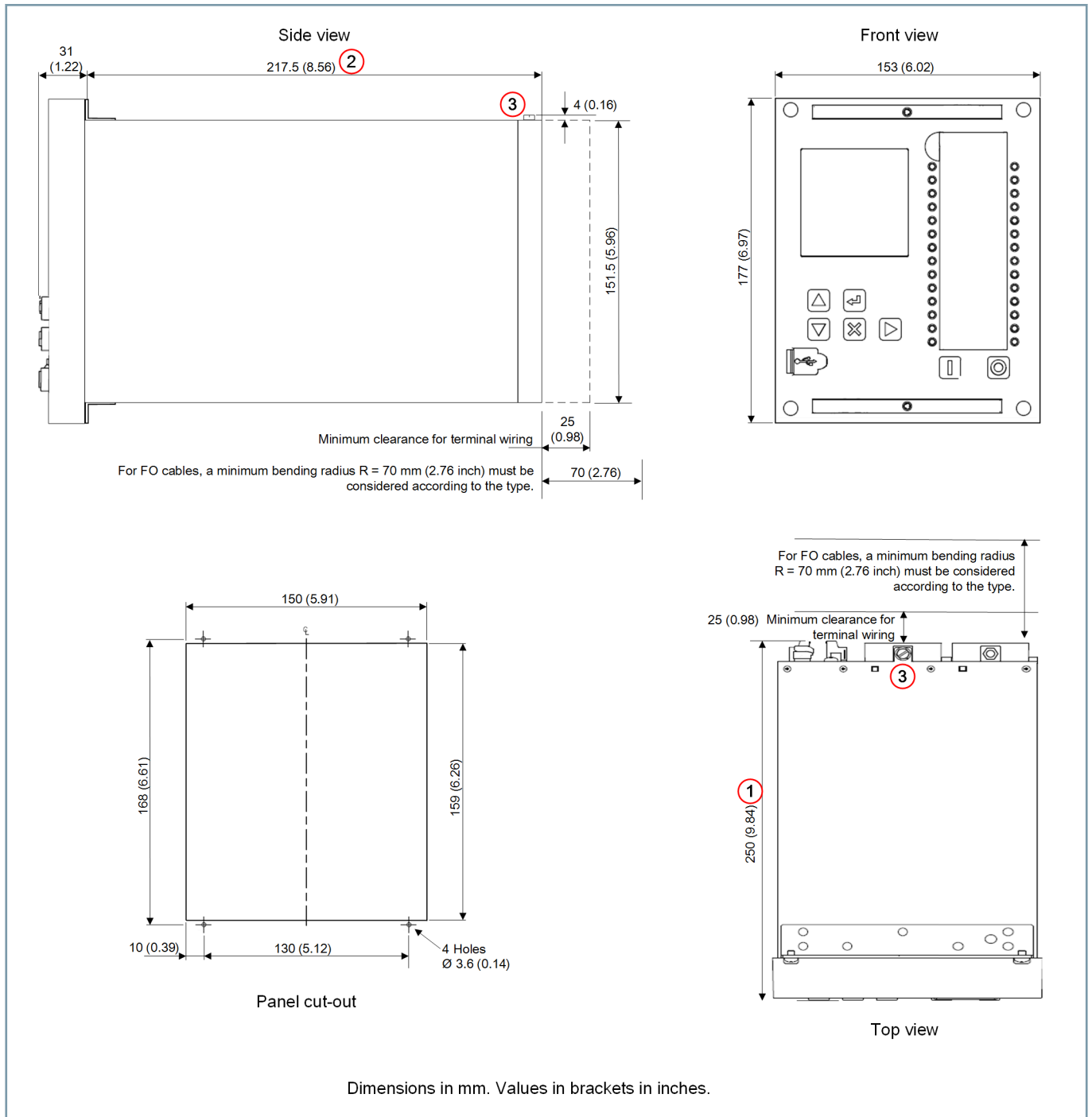

Figure 4.2/1 Size 6 Case: Dimensions and Panel Drilling Details

- (1) Overall length with AFD/RS485 plugs
- (2) Overall length to standard terminal blocks
- (3) Earth screw

**NOTE**

3.6 mm holes are suitable for M4 thread-forming screws supplied with the device for typical panel thickness.

Technical Documentation

Dimension drawings

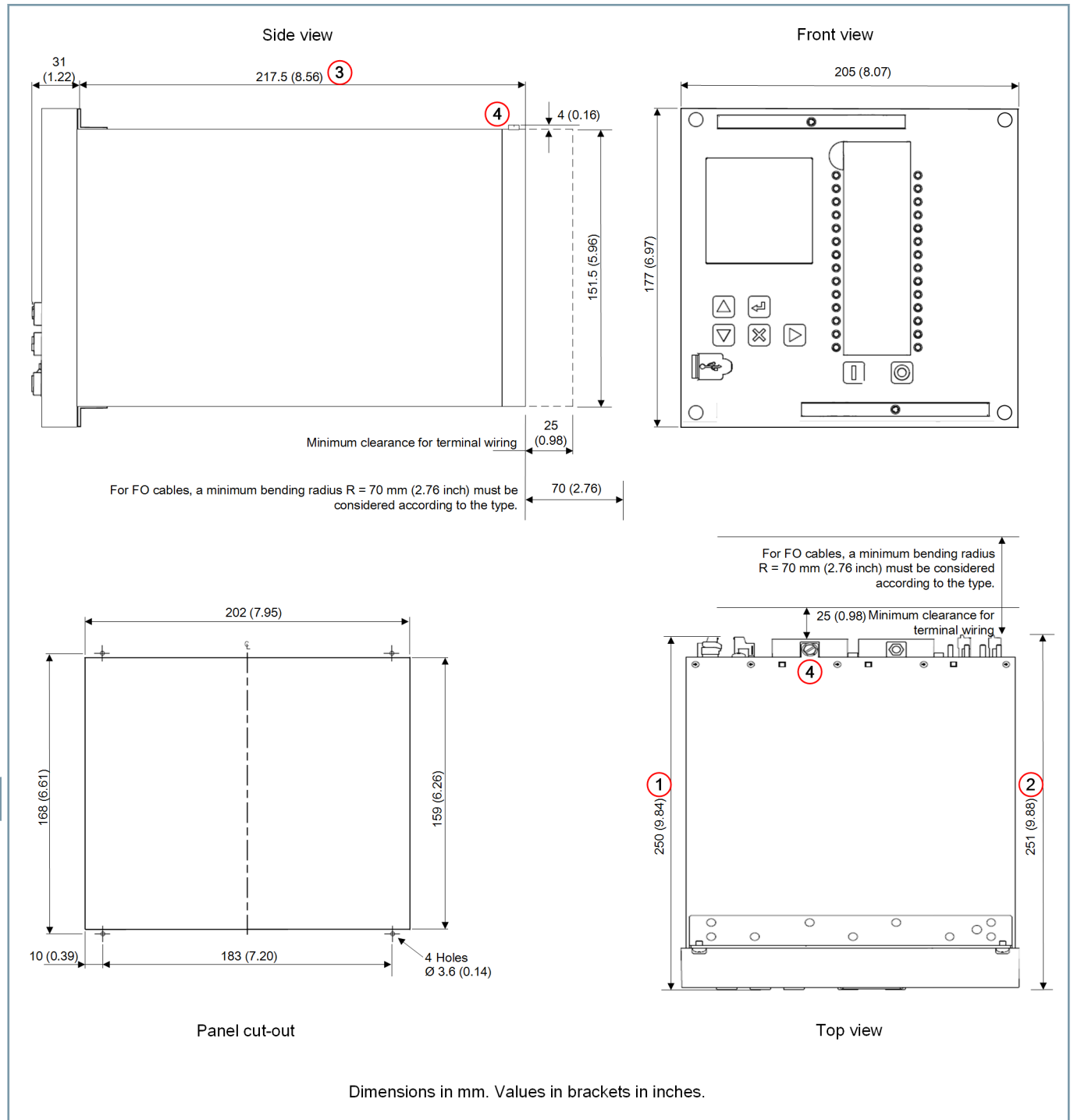

[dw_7SR5_E8_dimensions_2_en_US]

Figure 4.2/2 Size 8 Case: Dimensions and Panel Drilling Details

- (1) Overall length with AFD/RS485 plugs
- (2) Overall length with TSI plugs
- (3) Overall length to standard terminal blocks
- (4) Earth screw

**NOTE**

3.6 mm holes are suitable for M4 thread-forming screws supplied with the device for typical panel thickness.

Technical Documentation

Dimension drawings

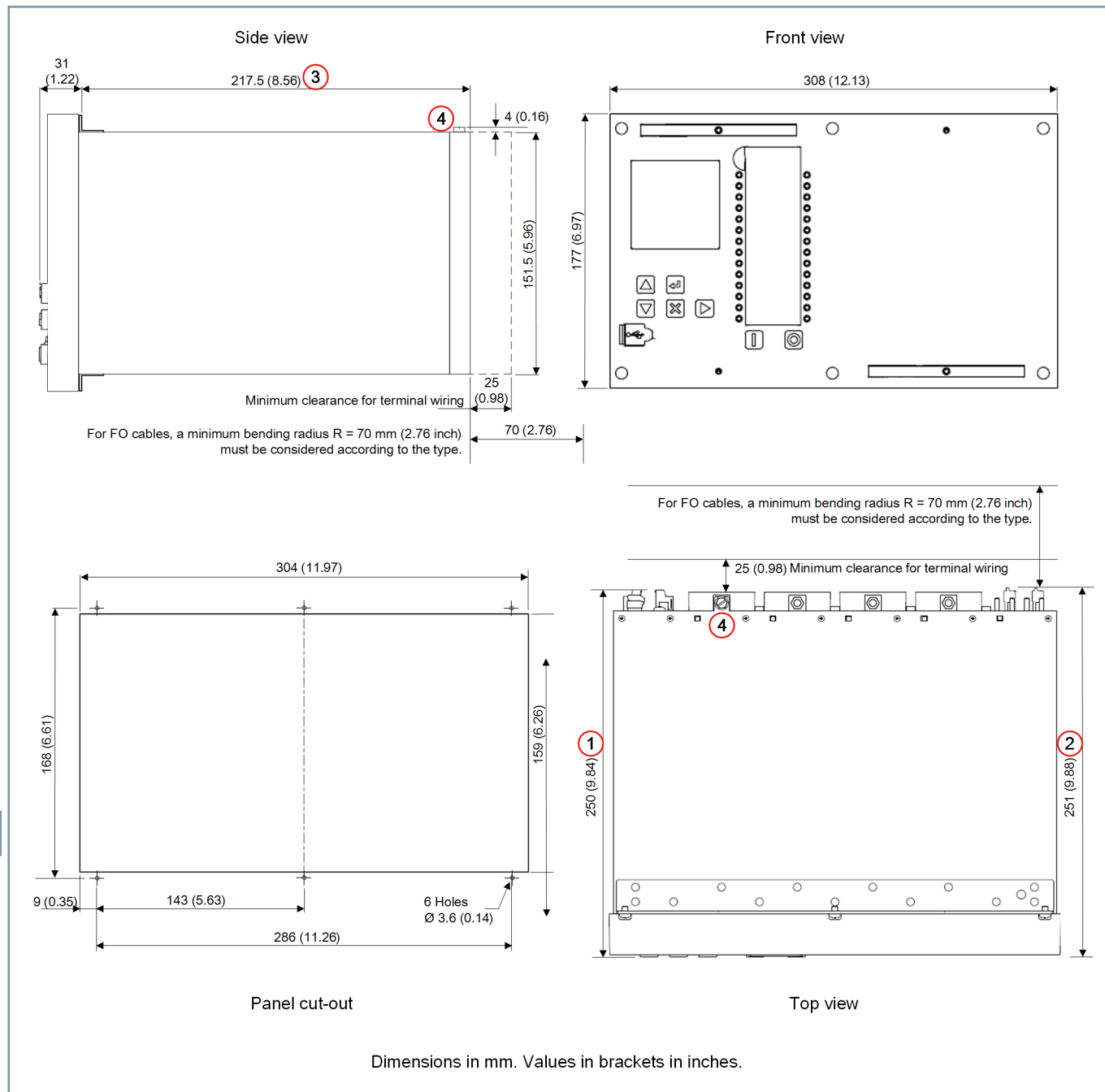

[dw_7SR5_E12_dimensions_5_en_US]

Figure 4.2/3 Size 12 Case: Dimensions and Panel Drilling Details

- (1) Overall length with AFD/RS485 plugs
- (2) Overall length with TSI plugs
- (3) Overall length to standard terminal blocks
- (4) Earth screw



NOTE

3.6 mm holes are suitable for M4 thread-forming screws supplied with the device for typical panel thickness.

Inputs and Outputs

Current Inputs

(IEC 60255-1, IEC 60255-27)

Quantity	See MLFB structure
Rated current I_{rated}	1 A/5 A
Measuring range	0.05 to $80 \cdot I_{rated}$ (phase) 0.005 to $32 \cdot I_{rated}$ (EF/SEF)
Sampling rate	32 samples per cycle
Instrumentation (0.1 to $2 \cdot I_{rated}$)	$\pm 1\%$ or $\pm 1\%$ I_{rated}
Nominal frequency	50 Hz/60 Hz
Thermal withstand:	
Continuous	$4.0 \cdot I_{rated}$ (20 A)
1 Second	$100 \cdot I_{rated}$ (500 A)
Burden @ I_{rated}	≤ 0.1 VA (phase and earth/SEF elements)

Voltage Inputs

(IEC 60255-1, IEC 60255-27)

Quantity	See MLFB structure
Rated voltage	AC 40 V to AC 160 V
Sampling rate	32 samples per cycle
Instrumentation (0.1 to $1.2 \cdot V_{rated}$)	$\pm 1\%$ or $\pm 1\%$ V_{rated}
Rated frequency	50 Hz/60 Hz
Thermal withstand:	
Continuous	300 V
Burden @ 110 V	≤ 0.1 VA

Optional Temperature Sensor Inputs

Value	Reference	Accuracy
RTD	Cu10, 0 °C to 540 °C	± 3 °C (0 °C to 250 °C)
	Ni100, 0 °C to 400 °C	± 1 °C (0 °C to 250 °C)
	Ni120, 0 °C to 330 °C	
	Ni250, 0 °C to 535 °C	
	Pt100, 0 °C to 540 °C	
	Pt250, 0 °C to 540 °C	
	Pt1000, 0 °C to 260 °C	± 2 °C (0 °C to 250 °C)
Thermistor	100 Ω to 30 K Ω	$\pm 2\%$ or ± 5 Ω

Auxiliary Supply

(IEC 60255-1, IEC 60255-26, IEC 60255-27)

Rated Voltage	Operating Range
DC 24 to 250 V	DC 19.2 V to DC 275 V
AC 100 to 230 V	AC 80 V to AC 253 V (50 Hz/60 Hz)

Rated Voltage	Quiescent Burden	Maximum Burden
DC 24 V	9.9 W	14.9 W
DC 48 V	9.3 W	14 W
DC 60 V	9.1 W	13.8 W

Rated Voltage	Quiescent Burden	Maximum Burden
DC 110 V	8.9 W	13.2 W
DC 125 V	8.8 W	13.2 W
DC 220 V	8.1 W	12.3 W
DC 250 V	8.3 W	12.5 W

Rated Voltage	Quiescent Burden	Maximum Burden
AC 100 V	20.8 VA	29.2 VA
AC 110 V	20.9 VA	30.1 VA
AC 115 V	21 VA	30.1 VA
AC 120 V	21.1 VA	30.6 VA
AC 200 V	23.2 VA	33.2 VA
AC 230 V	24.6 VA	34.7 VA

(IEC 60255-26)

Allowable superimposed AC component	$\leq 15\%$ of DC voltage
Allowable breaks/dips in supply (collapse to zero from nominal voltage)	≤ 50 ms

Binary Inputs

(IEC 60255-1, IEC 60255-26)

Operate voltage setting (user selectable)	DC 24 V/DC 110 V/DC 220 V
Maximum DC current for operation	2 mA
'High' level	$> 80\%$ V_{rated}
'Low' level	$< 40\%$ V_{rated}
Pick-up delay	0 to 14400 s
Dropoff delay	0 to 14400 s

Binary Outputs

(IEC 60255-1)

Operating voltage	AC 250 V/DC 250 V
Contact operate time	8 ms typical (standard binary output)
Release time	6 ms typical (standard binary output)
Making capacity	1000 W at L/R ≤ 40 ms
Carry continuously	AC 5 A or DC 5 A
Make and carry (\leq AC 250 V/DC 250 V)	30 A for 1 s
Breaking capacity (≤ 5 A and ≤ 250 V):	
AC resistive	1250 VA
DC resistive	75 W
DC inductive	30 W at L/R ≤ 40 ms
Mechanical endurance loaded	Make ≥ 1000 cycles Break ≥ 1000 cycles

Technical Documentation

Technical data

Mechanical Tests

Vibration – Sinusoidal

(IEC 60255-21-1 Class I)

Type	Level	Variation
Vibration response	0.5 gn	≤ 5 %
Vibration endurance	1.0 gn	≤ 5 %

Shock and Bump

(IEC 60255-21-2 Class I)

Type	Level	Variation
Shock response	5 gn, 11 ms	≤ 5 %
Shock withstand	15 gn, 11 ms	≤ 5 %
Bump test	10 gn, 16 ms	≤ 5 %

Seismic

(IEC 60255-21-3 Class I)

Type	Level	Variation
Seismic response	X-plane – 3.5 mm displacement below crossover frequency (8 to 9 Hz) 1 gn above.	≤ 5 %
	Y-plane – 1.5 mm displacement below crossover frequency (8 to 9 Hz) 0.5 gn above.	

IP Ratings

(IEC 60259)

Type	Level
Installed front face	IP 54
Rear enclosure(case)	IP 40
Rear wiring terminal access	IP 10 IP 20 achieved with optional terminal covers fitted

Product Safety

Protection Class

Protection class	I
------------------	---

Insulation – Dielectric Withstand

(IEC 60255-27)

Type	Level
Between any terminal and earth	AC 2.5 kV RMS for 1 min
Between independent circuits	
Across open contacts	AC 1.0 kV RMS for 1 min

Transient Overvoltage – Impulse Voltage Withstand

(IEC 60255-27)

Between all terminals and earth or between any 2 independent circuits	5 kV, 1.2/50 μs, 0.5 J
---	------------------------

Insulation Resistance

(IEC 60255-27)

Insulation resistance at 500 V	> 100 MΩ
--------------------------------	----------

Creepage Distances and Clearances

(IEC 60255-27)

Pollution degree	2
Overvoltage category	III

EMC Tests

Conducted Radio Frequency – Emissions

(IEC 60255-26)

Type	Limits	
	Quasi-peak	Average
0.15 MHz to 0.5 MHz	79 dB(μV)	66 dB(μV)
0.5 MHz to 30 MHz	73 dB(μV)	60 dB(μV)

Radiated Radio Frequency – Emissions

(IEC 60255-26)

Type	Limits at 3 m, Quasi-peak
30 MHz to 230 MHz	50 dB (μV/m)
230 MHz to 1 GHz	57 dB (μV/m)
1 GHz to 3 GHz	76 dB (μV/m)
3 GHz to 6 GHz	80 dB (μV/m)

Radiated Immunity

(IEC 60255-26)

Type	Level
80 MHz to 1000 MHz	Sweep 10 V/m
1.4 GHz to 2.7 GHz	Sweep 10 V/m
80 MHz, 160 MHz, 380 MHz, 450 MHz, 900 MHz, 1850 MHz, 2150 MHz	Spot 10 V/m

Electrostatic Discharge

(IEC 60255-26)

Type	Level	Variation
Contact discharge	8 kV	≤ 5 %
Air discharge	15 kV	≤ 5 %

Conducted Disturbance Induced by Radio Frequency Fields (IEC 60255-26)

Type	Level
0.15 MHz to 80 MHz	10 V

Fast Transient/Burst Immunity (IEC 60255-26 Zone A)

Type	Level	Variation
Case, aux power, I/O & earth	4 kV, 5 kHz	≤ 10 %
Metallic communications	2.0 kV, 5 kHz	No data loss

Slow Damped Oscillatory Wave/HF Disturbance (IEC 60255-26, IEC 61000-4-18)

Type	Level	Variation
Case, aux power & I/O: common (longitudinal) mode	2.5 kV	≤ 10 %
Case, aux power & I/O: differential (transverse) mode	1.0 kV	

Surge Immunity (IEC 60255-26 Zone A, IEC 61000-4-5)

Type	Level	Variation
Aux power & I/O: between all terminals and earth	4 kV	≤ 10 %
Aux power & I/O: between any two independent circuits	2 kV	
Communications	4 kV	No data loss

Power Frequency Disturbance (IEC 60255-26 Zone A, IEC 61000-4-16 level 4)

Type	Level 0 to 150 kHz
I/O common mode	300 V
I/O differential mode	150 V

Magnetic Field with Power Frequency (IEC 61000-4-8, level 5)

100 A/m (0.126 mT) continuous	50 Hz
1000 A/m (1.26 mT) for 3 s	

Climatic Tests

Temperature (IEC 60068-2-1/2)

Operating range	-10°C to +55°C
	-20 °C to +70 °C, 96 hrs ¹⁵
	-40 °C to +85 °C, 16 hrs ¹⁵
Storage range	-25°C to +70°C
	-40 °C to +85 °C, 96 hrs ¹⁵

Humidity (IEC 60068-2-78)

Operational test	56 days at 40°C and 93 % relative humidity
------------------	--

Corrosive Gas (IEC 60068-2-60)

Test Ke	Flowing mixed gas
---------	-------------------

Performance

Instrumentation

Current (0.1 to 2 · I _{rated})	±1 % or ±1 % · I _{rated}
Voltage (0.1 to 1.2 · V _{rated})	±1 % or ±1 % · V _{rated}
W Power (P)	±3 % S _{rated}
VAr Reactive power (Q)	
VA Apparent power (S)	
(S _{rated} = V _{rated} · I _{rated})	
V = V _{rated}	
I = 10 % to 200 % I _{rated}	
PF ≥ 0.8)	± 0.05
Power factor	
(V = V _{rated})	
I = 10 % to 200 % I _{rated}	± 10 mHz
PF ≥ 0.8)	
Frequency	± 10 mHz
(f _{rated} ± 5 %)	

21LB Load Blinder

I _{nps} (I ₂) setting (3Ph) (I _{set})	0.05 · I _{rated} to 5 · I _{rated}
I _{zps} (I ₀) setting (1Ph) (I _{set})	0.05 · I _{rated} to 5 · I _{rated}
V _{pps} (V ₁) setting	1 V to 110 V
Angle + setting	5° to 85°
Angle – setting	5° to 85°
Z _{set} Impedance setting	1Ω to 100Ω
I _{op} Operate level	I _{set} ± 5 % or ± 1 % I _{rated}

¹⁵ Basic hardware tested

Technical Documentation

Technical data

V _{op} Operate level	V _{set} ± 2 % or ± 0.5 V
V Reset level	110 % V _{op} ± 5 % V _{rated}
Angle operate level	± 5°
Impedance operate level	Z _{set} ± 5 % or ± 0.1Ω

24 Overexcitation Protection

Setting (V/Hz _{set})	0.1 to 2 p.u.
Hysteresis setting	0 to 80 %
Delay setting	0 to 14400 s
V/Hz _{op} (Operate level)	100 % V/Hz _{set} , ± 0.01 p.u.
Reset level	(100 % - hysteresis) · V/Hz _{op} , ± 0.01 p.u.
Basic operate time	t _{basic} + t _{delay} , ± 1 % or ± 10 ms
Operate time following delay	t _{basic} + t _{delay} , ± 1 % or ± 10 ms

27 Undervoltage Protection – 3-Phase

Operate	Any, all
Voltage guard	1 to 200 V
Setting V _{set}	5 to 200 V
Hysteresis setting	0 to 80 %
V _{op} Operate level	V _{set} ± 2 % or ± 0.5 V
Reset level	V _{op} + hysteresis, ± 2 % or 0.5 V
Delay setting t _{delay}	0 to 14400 s
Basic operate time t _{basic} : (1.1 to 0.5 · V _{set})	63 ms ± 10 ms
Operate time following delay	t _{basic} + t _{delay} , ± 1 % or ± 10 ms

27Vx Undervoltage Protection – Vx

Voltage guard	1 to 200 V
Setting V _{set}	5 to 200 V
Hysteresis setting	0 to 80 %
V _{op} Operate level	V _{set} ± 2 % or ± 0.5 V
Reset level	V _{op} + hysteresis, ± 2 % or 0.5 V
Delay setting t _{delay}	0 to 14400 s
Basic operate time t _{basic} : (1.1 to 0.5 · V _{set})	63 ms ± 10 ms
Operate time following delay	t _{basic} + t _{delay} , ± 1 % or ± 10 ms

32 Power Protection

Operation	Under, over
Power	P, Q or S
U/C guard	0.05 to 1 · I _{rated}
Setting S _{set}	0.05 to 2 · S _{rated}
Operate level S _{op}	S _{set} ± 5 % or ± 2 % S _{rated}
Reset level	≥ 95 % S _{op} (operation = over) ≤ 105 % S _{op} (operation = under)

Basic operate time t _{basic} : (1.1 · S _{set} (over))	60 ms ± 10 ms
(2 · S _{set} (over))	45 ms ± 10 ms
(0.5 · S _{set} (under))	40 ms ± 10 ms
Delay setting t _{delay}	0 to 14400 s
Operate time following delay	t _{basic} + t _{delay} , ± 1 % or ± 10 ms

37 Undercurrent Protection – Phase

Operate	Any, all
U/C guard	0.05 to 5 · I _{rated}
Setting range I _{set}	0.05 to 5 · I _{rated}
Operate level	I _{set} ± 5 % or ± 1 % · I _{rated}
Current guard	Phase 0.05 to 5 · I _{rated}
Delay setting t _{delay}	0 to 14400 s
Basic operate time t _{basic} : (1.1 to 0.5 · I _{rated})	40 ms ± 10 ms
Operate time following delay	t _{basic} + t _{delay} , ± 1 % or ± 10 ms
Overshoot time	< 40 ms

37G Undercurrent Earth Fault – Measured

Operate	Any, all
U/C guard	0.05 to 5 · I _{rated}
Setting range I _{set}	0.005 to 5 · I _{rated}
Operate level	I _{set} ± 5 % or ± 1 % · I _{rated}
Current guard	Phase 0.05 to 5 · I _{rated}
Delay setting t _{delay}	0 to 14400 s
Basic operate time t _{basic} : (1.1 to 0.5 · I _{rated})	40 ms ± 10 ms
Operate time following delay	t _{basic} + t _{delay} , ± 1 % or ± 10 ms
Overshoot time	< 40 ms

46 Negative-Sequence Overcurrent Protection

DT setting DT _{set}	0.05 to 4 · I _{rated}
DT operate level	DT _{set} ± 5 % or ± 1 % · I _{rated}
DT delay setting t _{delay}	0 to 14400 s
DT basic operate time t _{basic}	40 ms ± 10 ms (2 · DT _{set}) 30 ms ± 10 ms (5 · DT _{set})
DT operate time following delay	t _{basic} + t _{delay} , ± 1 % or ± 10 ms
IT char setting	IEC: NI,VI,EI,LTI ANSI: MI,VI,EI DTL
IT setting IT _{set}	0.05 to 2.5
Time multiplier Tm	0.025 to 100
IT operate level	105 % IT _{set} , ± 4 % or ± 1 % I _{rated}
Overshoot time	< 40 ms

46BC Broken Conductor Detection

U/C guard	0.05 to $5 \cdot I_{rated}$
Setting $(I_1/I_2)_{set}$	20 % to 100 %
Delay setting t_{delay}	0.03 to 14400 s
Operate level I_{op}	$(I_2/I_1)_{set} \pm 5 \%$
Basic operate time t_{basic}	40 ms \pm 10 ms
Operate time following delay	$t_{basic} + t_{delay} \pm 1 \%$ or ± 20 ms

47 Sequence Overvoltage Protection

Setting V_{set}	1 V to 90 V
Hysteresis setting	0 to 80 %
Operate level	$V_{set} \pm 2 \%$ or ± 0.5 V
Delay setting t_{delay}	0 to 14400 s
Basic operate time t_{basic} :	
(0 V to $1.5 \cdot V_{set}$)	80 ms \pm 20 ms
(0 V to $10 \cdot V_{set}$)	55 ms \pm 20 ms
Operate time following delay	$t_{basic} + t_{delay} \pm 2 \%$ or ± 20 ms
Overshoot time	< 40 ms

49 Thermal Overload Protection

Setting I_{set}	0.1 to $3 \cdot I_{rated}$
Operate level	$I_{set} \pm 5 \%$ or $\pm 1 \%$ $\cdot I_{rated}$
Time constant setting	1 to 1000 min
Operate time	$T = \tau \cdot \ln \left[\frac{I^2 - I_p^2}{I^2 - I_\theta^2} \right]$ <p>$\pm 5 \%$ or ± 100 ms $(I_{set}: 0.3 \text{ to } 3 \cdot I_{rated})$ $I =$ Average rms current $I_p =$ Pre-load current $I_\theta =$ Thermal overload setting current $\tau =$ Thermal heating time constant (minutes) $\ln =$ Natural logarithm $t =$ Operate time (minutes)</p>

49M Motor Thermal Overload Protection

Setting I_{set}	0.1 to $3 \cdot I_{rated}$
NPS weighting factor (K)	0.1 to 10, $\Delta 0.1$
TauH heating constant	0.5 to 1000 min, $\Delta 0.5$ min
TauS starting constant	0.005 to 1 \cdot TauH, $\Delta 0.005$
TauC cooling constant	1 to 100 \cdot TauH, $\Delta 1$
Hot/cold ratio	Off, 1 to 100 %, $\Delta 1 \%$
Operate level	$I_{set} \pm 5 \%$ or $\pm 1 \%$ $\cdot I_{rated}$

Operate time	$t = \tau \cdot \ln \left\{ \frac{I_{EQ}^2 - \left(1 - \frac{H}{C}\right) I_p^2}{I_{EQ}^2 - I_\theta^2} \right\}$ <p>$\pm 5 \%$ or ± 100 ms $(I_{set}: 0.3 \text{ to } 3 \cdot I_{rated})$ $I =$ Average rms current $I_p =$ Pre-load current $I_\theta =$ Thermal overload setting current $\tau =$ Thermal heating time constant (minutes) $\ln =$ Natural logarithm $t =$ Operate time (minutes)</p>
Capacity alarm level	Disabled, 50 to 100 %
Load alarm level	Off, 0.5 to 1 $\cdot I_\theta$, $\Delta 0.05$
Thermal restart inhibit	20 to 100 %, $\Delta 1 \%$
Inhibited by	Binary or virtual input

50 Instantaneous Overcurrent – Phase

Operation ¹⁶	Non-directional, forward or reverse (see 67)
Setting I_{set}	0.05 to $25 \cdot I_{rated}$
Delay setting t_{delay}	0 to 14400 s
Operate level I_{op}	$I_{set} \pm 5 \%$ or $\pm 1 \%$ $\cdot I_{rated}$
Reset level	$\geq 95 \%$ I_{op}
Basic operate time t_{basic}	35 ms \pm 10 ms ($2 \cdot I_{set}$) 25 ms \pm 10 ms ($5 \cdot I_{set}$)
Operate time following delay	$t_{basic} + t_{delay} \pm 1 \%$ or ± 10 ms

50AFD Arc Flash Detection

Setting I_{set}	1 to $10 \cdot I_{rated}$
Operate level I_{op}	$I_{set} \pm 10 \%$
Reset level	$\geq 95 \%$ I_{op}
Operate time (Optional AFD/HSBO module)	< 6 ms (HSBO), light only > 12 ms (HSBO), light and current

50BF Circuit-Breaker Failure Protection – 3 Pole

Setting I_{set}	0.05 to $2 \cdot I_{rated}$
Time delays t_{delay}	Timer 1: 20 to 60000 ms Timer 2: 20 to 60000 ms
Operate level	$I_{set} \pm 5 \%$ or $\pm 1 \%$ $\cdot I_{rated}$
Operate time following delay	$t_{delay} \pm 1 \%$ or ± 20 ms

¹⁶ Requires VT inputs

Technical Documentation

Technical data

50G Instantaneous Earth Fault – Measured

Operation ¹⁶	Non-directional, forward or reverse (see 67G)
Setting I_{set}	0.005 to $25 \cdot I_{rated}$
Delay setting t_{delay}	0 to 14400 s
Operate level I_{op}	$I_{set} \pm 5\%$ or $\pm 1\% I_{rated}$
Reset level	$\geq 95\% I_{op}$
Basic operate time t_{basic}	$35\text{ ms} \pm 10\text{ ms}$ ($2 \cdot I_{set}$)
	$25\text{ ms} \pm 10\text{ ms}$ ($5 \cdot I_{set}$)
Operate time following delay	$t_{basic} + t_{delay} \pm 1\%$ or $\pm 10\text{ ms}$

50GHS High Speed Earth Fault – Measured

Setting I_{set}	0.5 to $25 \cdot I_{rated}$
Delay setting t_{delay}	0 to 14400 s
Operate level I_{op}	$I_{set} \pm 5\%$ or $\pm 1\% I_{rated}$
Reset level	$\geq 95\% I_{op}$
Basic operate time t_{basic}	$20\text{ ms} \pm 4\text{ ms}$ ($2 \cdot I_{set}$)
	$14\text{ ms} \pm 4\text{ ms}$ ($5 \cdot I_{set}$)
Operate time following delay	$t_{basic} + t_{delay} \pm 1\%$ or $\pm 10\text{ ms}$

50GI Intermittent Earth Fault

Setting I_{set}	0.005 to $2 \cdot I_{rated}$
Applied current pulse duration	$> 5\text{ ms}$
Minimum time between current pulses	40 ms
Operate level I_{op}	$I_{set} \pm 5\%$ or $\pm 1\% I_{rated}$
Pickup Time at $4 \cdot I_{set}$	$20\text{ ms} \pm 5\text{ ms}$
Basic operate time t_{basic}	$\pm 1\%$ or $\pm 10\text{ ms}$ for each pulse

50GS Instantaneous Sensitive Earth Fault – Measured

Operation ¹⁶	Non-directional, forward or reverse (see 67GS)
Setting I_{set}	0.005 to $1 \cdot I_{rated}$
Delay setting t_{delay}	0 to 14400 s
Operate level I_{op}	$I_{set} \pm 5\%$ or $\pm 1\% I_{rated}$
Reset level	$\geq 95\% I_{op}$
Basic operate time t_{basic}	$35\text{ ms} \pm 10\text{ ms}$ ($2 \cdot I_{set}$)
	$25\text{ ms} \pm 10\text{ ms}$ ($5 \cdot I_{set}$)
Operate time following delay	$t_{basic} + t_{delay} \pm 1\%$ or $\pm 10\text{ ms}$

50HS High Speed Overcurrent – Phase

Setting I_{set}	0.5 to $50 \cdot I_{rated}$
Delay setting t_{delay}	0 to 14400 s
Operate level I_{op}	$I_{set} \pm 5\%$ or $\pm 1\% \cdot I_{rated}$
Reset level	$\geq 95\% I_{op}$

Basic operate time t_{basic}	$20\text{ ms} \pm 4\text{ ms}$ ($2 \cdot I_{set}$)
	$14\text{ ms} \pm 4\text{ ms}$ ($5 \cdot I_{set}$)
Operate time following delay	$t_{basic} + t_{delay} \pm 1\%$ or $\pm 10\text{ ms}$

50N Instantaneous Earth Fault – Calculated

Operation ¹⁶	Non-directional, forward or reverse (see 67N)
Setting I_{set}	0.05 to $50 \cdot I_{rated}$
Delay setting t_{delay}	0 to 14400 s
Operate level I_{op}	$I_{set} \pm 5\%$ or $\pm 1\% I_{rated}$
Reset level	$\geq 95\% I_{op}$
Basic operate time t_{basic}	$40\text{ ms} \pm 10\text{ ms}$ ($2 \cdot I_{set}$)
	$30\text{ ms} \pm 10\text{ ms}$ ($5 \cdot I_{set}$)
Operate time following delay	$t_{basic} + t_{delay} \pm 1\%$ or $\pm 10\text{ ms}$

51 Time-Delayed Overcurrent – Phase

51V Setting V_{set} ¹⁶	5 V to 200 V
51V Operate level	$V_{set} \pm 5\%$ or $\pm 1\% V_{rated}$
51CL Reduced current level	0.05 to $2.5 \cdot I_{rated}$
Measurement	RMS, fundamental
Directional control ¹⁶	Non-directional, forward or reverse (see 67)
Setting I_{set}	0.05 to $2.5 \cdot I_{rated}$
Characteristic	IEC: NI,VI,EI,LTI
	ANSI: MI,VI,EI
	DTL
Time multiplier T_m	0.025 to 100
Delay setting (DTL)	0 to 20 s
Minimum operate time	0 to 20 s
Follower delay	0 to 20 s
Reset	ANSI decaying
	0 to 60 s
51V Multiplier ¹⁶	0.25 to 1
Operate level	$105\% I_{set} \pm 4\%$ or $\pm 1\% \cdot I_{rated}$

Basic operate time t_{basic}	$20 \text{ ms} \pm 20 \text{ ms} (2 \cdot I_{set})$
Operate time	
IEC	$t_{op} = \left[\frac{K}{\left(\frac{I}{I_{set}}\right)^\alpha - 1} \right] \cdot T_m$ <p>$\pm 5 \% \text{ or } \pm 30 \text{ ms}$</p>
ANSI	$t_{op} = \left[\frac{A}{\left(\frac{I}{I_{set}}\right)^P - 1} + B \right] \cdot T_m$ <p>$\pm 5 \% \text{ or } \pm 30 \text{ ms}$</p>
DTL	DTL $\pm 1 \% \text{ or } \pm 20 \text{ ms}$

Basic operate time t_{basic}	$20 \text{ ms} \pm 20 \text{ ms} (2 \cdot I_{set})$
Operate time	
IEC	$t_{op} = \left[\frac{K}{\left(\frac{I}{I_{set}}\right)^\alpha - 1} \right] \cdot T_m$ <p>$\pm 5 \% \text{ or } \pm 30 \text{ ms}$</p>
ANSI	$t_{op} = \left[\frac{A}{\left(\frac{I}{I_{set}}\right)^P - 1} + B \right] \cdot T_m$ <p>$\pm 5 \% \text{ or } \pm 30 \text{ ms}$</p>
DTL	DTL $\pm 1 \% \text{ or } \pm 20 \text{ ms}$

51G Time-Delayed Earth Fault – Measured

Measurement	RMS, fundamental
Directional Control ¹⁶	Non-directional, forward or reverse (see 67G)
Setting I_{set}	$0.005 \text{ to } 1 \cdot I_{rated}$
Characteristic	IEC: NI,VI,EI,LT1 ANSI: MI,VI,EI DTL
Time multiplier T_m	0.025 to 100
Delay setting (DTL)	0 to 20 s
Minimum operate time	0 to 20 s
Follower delay	0 to 20 s
Reset	ANSI decaying 0 to 60 s
51V Multiplier ¹⁶	0.25 to 1
Operate level	$105 \% I_{setv} \pm 4 \% \text{ or } \pm 1 \% \cdot I_{rated}$

51GS Time-Delayed Sensitive Earth Fault – Measured

Directional Control ¹⁶	Non-directional, forward or reverse (see 67GS)
Setting I_{set}	$0.005 \text{ to } 1 \cdot I_{rated}$
Characteristic	IEC: NI,VI,EI,LT1 ANSI: MI,VI,EI DTL
Time multiplier T_m	0.025 to 100
Delay setting (DTL)	0 to 20 s
Minimum operate time	0 to 20 s
Follower delay	0 to 20 s
Reset	ANSI decaying 0 to 60 s
51V Multiplier ¹⁶	0.25 to 1
Operate level	$105 \% I_{setv} \pm 4 \% \text{ or } \pm 1 \% \cdot I_{rated}$
Basic operate time t_{basic}	$20 \text{ ms} \pm 20 \text{ ms} (2 \cdot I_{set})$
Operate time	
IEC	$t_{op} = \left[\frac{K}{\left(\frac{I}{I_{set}}\right)^\alpha - 1} \right] \cdot T_m$ <p>$\pm 5 \% \text{ or } \pm 30 \text{ ms}$</p>
ANSI	$t_{op} = \left[\frac{A}{\left(\frac{I}{I_{set}}\right)^P - 1} + B \right] \cdot T_m$ <p>$\pm 5 \% \text{ or } \pm 30 \text{ ms}$</p>
DTL	DTL $\pm 1 \% \text{ or } \pm 20 \text{ ms}$

Technical Documentation

Technical data

51N Time-Delayed Earth Fault – Calculated

Directional Control ¹⁶	Non-directional, forward or reverse (see 67G)
Setting I_{set}	0.05 to $2.5 \cdot I_{rated}$
Characteristic	IEC: NI,VI,EI,LT1 ANSI: MI,VI,EI DTL
Time multiplier T_m	0.025 to 100
Delay setting (DTL)	0 to 20 s
Minimum operate time	0 to 20 s
Follower delay	0 to 20 s
Reset	ANSI decaying 0 to 60 s
51V Multiplier ¹⁶	0.25 to 1
Operate level	$105\% I_{set} \pm 4\%$ or $\pm 1\% \cdot I_{rated}$
Basic operate time t_{basic}	$20\text{ ms} \pm 20\text{ ms} (2 \cdot I_{set})$
Operate time	
IEC	$t_{op} = \left[\frac{K}{\left(\frac{I}{I_{set}}\right)^\alpha - 1} \right] \cdot T_m$ <p>$\pm 5\%$ or $\pm 30\text{ ms}$</p>
ANSI	$t_{op} = \left[\frac{A}{\left(\frac{I}{I_{set}}\right)^P - 1} + B \right] \cdot T_m$ <p>$\pm 5\%$ or $\pm 30\text{ ms}$</p> <p>DTL $\pm 1\%$ or $\pm 20\text{ ms}$</p>
DTL	

Basic operate time t_{basic}	$73\text{ ms} \pm 10\text{ ms} (1.1 \cdot V_{set})$ $63\text{ ms} \pm 10\text{ ms} (2 \cdot V_{set})$
Operate time following delay	$t_{basic} + t_{delay}$, $\pm 1\%$ or $\pm 10\text{ ms}$

59N Neutral Voltage Displacement

DT setting DT_{set}	1 to 100 V
DT operate level	$DT_{set} \pm 2\%$ or $\pm 0.5\text{ V}$
DT delay setting t_{delay}	0 to 14400 s
DT basic operate time t_{basic}	$76\text{ ms} \pm 20\text{ ms} (1.5 \cdot DT_{set})$ $63\text{ ms} \pm 20\text{ ms} (10 \cdot DT_{set})$
DT operate time following delay	$t_{basic} + t_{delay}$, $\pm 1\%$ or $\pm 20\text{ ms}$
IT char setting	IDMTL and DTL
IT setting IT_{set}	1 to 100 V
Time multiplier T_m	0.1 to 140
Delay (DTL)	0 to 20 s
Reset	ANSI decaying 0 to 60 s
IT operate level	$IT_{set} \pm 2\%$ or $\pm 0.5\text{ V}$

59Vx Overvoltage Protection – Vx

Setting V_{set}	5 to 200 V
Hysteresis setting	0 to 80 %
Operate level	$V_{set} \pm 2\%$ or $\pm 0.5\text{ V}$
Reset level	V_{op} - hysteresis, $\pm 2\%$ or 0.5 V
Delay setting t_{delay}	0 to 14400 s
Basic operate time t_{basic}	$73\text{ ms} \pm 10\text{ ms} (1.1 \cdot V_{set})$ $63\text{ ms} \pm 10\text{ ms} (2 \cdot V_{set})$
Operate time following delay	$t_{basic} + t_{delay}$, $\pm 1\%$ or $\pm 10\text{ ms}$

60CTS-I CT Supervision – Current Reference

CTS-I setting I_{set}	0.05 to $2 \cdot I_{rated}$
Delay setting t_{delay}	0.03 to 14400 s
Basic operate time t_{basic}	$30\text{ ms} \pm 20\text{ ms}$
Operate time following delay	$t_{basic} + t_{delay}$, $\pm 1\%$ or $\pm 20\text{ ms}$

60CTS-V CT Supervision – Voltage Reference

CTS-V $I_{nps} (I_2)$ setting I_{nps}	0.05 to $1 \cdot I_{rated}$
CTS-V $V_{nps} (V_2)$ setting V_{nps}	7 to 110 V
Delay setting t_{delay}	0.03 to 14400 s
Basic operate time t_{basic}	$30\text{ ms} \pm 20\text{ ms}$
Operate time following delay	$t_{basic} + t_{delay}$, $\pm 1\%$ or $\pm 20\text{ ms}$

60VTS VT Supervision

Component setting	NPS, ZPS
Current setting I_{set}	0.05 to $1 \cdot I_{rated}$
Voltage setting V_{set}	7 to 110 V

55 Power Factor

Operation setting	Under, over
Directional control	Non-Directional, lead, lag
U/C guard setting	0.05 to 1
Setting PF_{set}	0.05 to 0.99
Delay setting t_{delay}	0 to 14400 s
Operate level	$PF_{set} \pm 0.05$
Basic operate time t_{basic}	$\leq 70\text{ ms}$
Operate time following delay	$t_{basic} + t_{delay} \pm 1\%$ or $\pm 10\text{ ms}$

59 Overvoltage Protection – 3 Phase

Operate	Any, all
Setting V_{set}	5 to 200 V
Hysteresis setting	0 to 80 %
Operate level	$V_{set} \pm 2\%$ or $\pm 0.5\text{ V}$
Reset level	V_{op} - hysteresis, $\pm 2\%$ or 0.5 V
Delay setting t_{delay}	0 to 14400 s

V_{pp5} (V_1) setting	1 to 110 V
I_{pp5} (I_1) load setting	0.05 to $1 \cdot I_{rated}$
I_{pp5} (I_1) fault setting	0.05 to $20 \cdot I_{rated}$
Delay setting t_{delay}	0.03 to 14400 s
Basic operate time t_{basic}	32 ms \pm 10 ms
Operate time following delay	$t_{basic} + t_{delay}$, $\pm 1\%$ or ± 10 ms

67 Directional Overcurrent – Phase

Angle setting θ_{set}	-95° to +95°
Minimum voltage setting	1 V to 20 V
Operating angle	$\theta_{set} - 85^\circ \pm 5^\circ$ to $\theta_{set} - 85^\circ \pm 5^\circ$ (Forward)
Minimum operating voltage	> 1 V \pm 0.25 V
Operate time	Typically 32 ms < 40 ms at characteristic angle
Reset time	< 65 ms at characteristic angle

67G Directional Earth Fault – Measured

Angle setting θ_{set}	-95° to +95°
Minimum voltage setting	0.33 V to 3 V
Operating angle	$\theta_{set} - 85^\circ \pm 5^\circ$ to $\theta_{set} - 85^\circ \pm 5^\circ$ (Forward)
Minimum operating voltage	> 0.33 V \pm 0.25 V
Operate time	Typically 32 ms < 40 ms at characteristic angle
Reset time	< 65 ms at characteristic angle

67G1 Directional Intermittent Earth Fault

Angle setting θ_{set}	-95° to +95°
Minimum voltage setting	0.33 V to 3 V
Operating angle	$\theta_{set} - 85^\circ \pm 5^\circ$ to $\theta_{set} - 85^\circ \pm 5^\circ$ (Forward)
Minimum operating voltage	> 0.33 V \pm 0.25 V
Operate time	< 25 ms at characteristic angle
Reset time	< 25 ms at characteristic angle

67GS Directional Sensitive Earth Fault – Measured

Angle setting θ_{set}	-95° to +95°
Minimum voltage setting	0.33 V to 3 V
Operating angle	$\theta_{set} - 85^\circ \pm 5^\circ$ to $\theta_{set} - 85^\circ \pm 5^\circ$ (Forward)
Minimum operating voltage	> 0.33 V \pm 0.25 V
Operate time	Typically 32 ms < 40 ms at characteristic angle
Reset time	< 65 ms at characteristic angle

67N Directional Earth Fault – Calculated

Angle setting θ_{set}	-95° to +95°
Minimum voltage setting	0.33 V to 3 V

Operating angle	$\theta_{set} - 85^\circ \pm 5^\circ$ to $\theta_{set} - 85^\circ \pm 5^\circ$ (Forward)
Minimum operating voltage	> 0.33 V \pm 0.25 V
Operate time	Typically 32 ms < 40 ms at characteristic angle
Reset time	< 65 ms at characteristic angle

78VS Voltage Vector Shift

Angle setting θ_{set}	2° to 30°
Operate level	$\theta_{set} \pm 2^\circ$
Operate time	≤ 40 ms

79 Automatic Reclosing

Operating mode	Phase, earth, SEF, external
Number of reclosures	4
Number of trips	5
Dead time	0 to 14400 s
Reclaim time	0 to 600 s

81 Frequency Protection – "f>" or "f<"

Setting f_{set}	43 Hz to 68 Hz
Hysteresis setting	0 to 2 %
Delay setting t_{delay}	0 to 14400 s
Operate level	$f_{set} \pm 10$ mHz
Basic operate time t_{basic}	< 150 ms
Operate time following delay	$t_{basic} + t_{delay}$, $\pm 1\%$ or ± 10 ms

81R Frequency Protection – "df/dt"

Setting df/dt_{set}	0.05 to 10 Hz/s
Hysteresis setting	0 to 2 %
Delay setting t_{delay}	0 to 14400 s
Operate level	$df/dt_{set} \pm 50$ mHz/s
Basic operate time t_{basic}	< 200 ms, typically < 185 ms ($2 \cdot df/dt_{set}$)
Operate time following delay	$t_{basic} + t_{delay}$, $\pm 1\%$ or ± 10 ms

87GH Restricted Earth-Fault Protection – High-Impedance

Setting I_{set}	0.005 to $0.95 \cdot I_{rated}$
Delay setting t_{delay}	0 to 14400 s
Operate level	$I_{set} \pm 5\%$ or $\pm 1\% \cdot I_{rated}$
Basic operate time t_{basic}	$3 \cdot I_{op} < 30$ ms (device firmware V2.30 onwards) $3 \cdot I_{op} < 45$ ms (prior to device firmware V2.30)
Operate time following delay	$t_{basic} + t_{delay}$, $\pm 1\%$ or ± 10 ms

Technical Documentation

Technical data

87M-BD Motor Differential Protection – Biased

Differential settings:	
Initial setting I_{set}	$0.05 \cdot I_{rated}$ to $2 \cdot I_{rated}$
S1 (1 st bias slope)	0.1x to 0.7x
S1L (1 st bias slope limit)	$1 \cdot I_{rated}$ to $20 \cdot I_{rated}$
S2 (2 nd bias slope)	0.4x to 2x
Delay setting t_{delay}	0 to 1 s
Operate level	$SOL = \frac{I_s}{S1}$
$I_{op} = [I_{W1} + I_{W2}]$	$I_{BIAS} = 0$ to SOL: $I_{op} > I_s$
$I_{BIAS} = \frac{[I_{W1} + I_{W2}]}{2}$	I_{BIAS} SOL to S1L: $I_{op} > S1(I_{BIAS} - SOL) + I_s$
	$I_{BIAS} > S1L$: $I_{op} > S2(I_{BIAS} - S1L) + S1(S1L - SOL) + I_s$
Reset level	$> 90\% I_{op}$
Basic operate time t_{basic} : (inrush action enabled)	< 30 ms ($\geq 3 \cdot I_{op}$)
Operate time following delay	$t_{basic} + t_{delay}$, $\pm 1\%$ or ± 10 ms

87M-HS Motor Differential Protection – Highset

Differential setting I_{set}	1 to $30 \cdot I_{rated}$
Delay setting t_{delay}	0 to 1 s
Operate level	$\pm 10\%$ of setting or $\pm 0.01 I_{rated}$
Reset level	$> 90\% I_{op}$
Basic operate time t_{basic} : (inrush action enabled)	$I_{op} = [I_{W1} + I_{W2}]$
	< 25 ms ($\geq 1.5 \cdot I_{op}$)
Operate time following delay	$t_{basic} + t_{delay}$, $\pm 1\%$ or ± 10 ms

87NL Restricted Earth-Fault Protection – Low-Impedance

Guard setting	0.05 to $5 \cdot I_{rated}$
Differential settings:	
Initial setting I_{set}	$0.05 \cdot I_{rated}$ to $2 \cdot I_{rated}$
S1 (1 st bias slope)	0.1x to 0.7x
S1L (1 st bias slope limit)	$0.5 \cdot I_{rated}$ to $2 \cdot I_{rated}$
S2 (2 nd bias slope)	1x to 2x
Delay setting t_{delay}	0 to 1 s

Operate level	$I_{op} = I_n \pm I_g $
	$I_{BIAS} = \frac{ I_g + I_n }{2}$
	$I_{BIAS} = 0$ p.u. to 1 p.u.: $I_{op} > I_{set}$
	$I_{BIAS} = 1$ p.u. to S1L: $I_{op} > S1 - 1 + I_{set}$
	$I_{BIAS} > S1L$: $I_{op} > S2(I_{BIAS} - S1L) + S1(S1L - 1) + I_{set}$
	$\pm 10\%$ of setting or $\pm 0.01 I_{rated}$
Reset level	$> 90\% I_{op}$
Basic operate time t_{basic} :	< 30 ms ($\geq 3 \cdot I_{op}$)
Operate time following delay	$t_{basic} + t_{delay}$, $\pm 1\%$ or ± 10 ms

87T-BD Transformer Differential Protection – Biased

Differential settings:	
Initial setting I_{set}	$0.05 \cdot I_{rated}$ to $2 \cdot I_{rated}$
S1 (1 st bias slope)	0.1x to 0.7x
S1L (1 st bias slope limit)	$1 \cdot I_{rated}$ to $20 \cdot I_{rated}$
S2 type (bias slope 2)	Line, curve
S2 (2 nd bias slope)	1x to 2x
Delay setting t_{delay}	0 to 1 s
Operate level	$SOL = \frac{I_s}{S1}$
$I_{op} = [I_{W1} + I_{W2} + I_{W3}]$	$I_{BIAS} = 0$ to SOL: $I_{op} > I_s$
$I_{BIAS} = \frac{[I_{W1} + I_{W2} + I_{W3}]}{2}$	I_{BIAS} SOL to S1L: $I_{op} > S1(I_{BIAS} - SOL) + I_s$
	$I_{BIAS} > S1L$: $I_{op} > S2(I_{BIAS} - S1L) + S1(S1L - SOL) + I_s$
Reset level	$> 90\% I_{op}$
Basic operate time t_{basic} : (inrush action enabled)	< 30 ms ($\geq 3 \cdot I_{op}$)
Operate time following delay	$t_{basic} + t_{delay}$, $\pm 1\%$ or ± 10 ms

87T-HS Transformer Differential Protection – Highset

Differential setting I_{set}	1 to $30 \cdot I_{rated}$
Delay setting t_{delay}	0 to 1 s
Operate level	$\pm 10\%$ of setting or $\pm 0.01 I_{rated}$
Reset level	$> 90\% I_{op}$
Basic operate time t_{basic} : (inrush action enabled)	$I_{op} = [I_{W1} + I_{W2} + I_{W3}]$
	< 25 ms ($\geq 1.5 \cdot I_{op}$)
Operate time following delay	$t_{basic} + t_{delay}$, $\pm 1\%$ or ± 10 ms

Control Functions

CB	Open, close
Inst prot	In/out

EF	In/out
SEF	In/out
Hot line	In/out
Relay mode	Local, remote, local or remote
Reset	LEDs & binary outputs

Circuit-Breaker Maintenance

Total trip counter	0 to 10000
Delta trip counter	0 to 10000
Counts to AR block	0 to 10000
Frequent operations	0 to 10000
I ² t alarm	10 to 100000

Technical Documentation

Ordering Information

Ordering Information – 7SR51 Overcurrent Protection Relay

Product Description	Order No.																	
	1	2	3	4	5	6	7	8	9	10	11	12	13	14	15	16		
7SR51 Overcurrent Protection Relay	7	S	R	5	1	n	n	-	n	A	a	n	n	-	n	A	A	0
								-					-					
<i>Overcurrent: I/O Configurations</i>						<u>6</u>	<u>Z</u>	-	<u>8</u>		<u>10</u>		<u>12</u>	-				
4 I, 8 BI, 6 BO						1	0	-	1		A		1	-				
4 I, 3 AFD, 8 BI, 9 BO (inc. 3 HSBO)						1	0	-	1		D		1	-				
4 I, 13 BI, 8 BO						1	0	-	2		A		1	-				
4 I, 3 AFD, 13 BI, 11 BO (inc. 3 HSBO)						1	0	-	2		D		1	-				
4 I, 8 TSI, 13 BI, 8 BO						1	0	-	2		F		1	-				
4 I, 18 BI, 10 BO						1	0	-	3		A		2	-				
4 I, 3 AFD, 18 BI, 13 BO (inc. 3 HSBO)						1	0	-	3		D		2	-				
4 I, 8 TSI, 18 BI, 10 BO						1	0	-	3		F		2	-				
4 I, 23 BI, 12 BO						1	0	-	4		A		2	-				
4 I, 23 BI, 12 BO						1	0	-	4		A		6	-				
4 I, 3 AFD, 23 BI, 15 BO (inc. 3 HSBO)						1	0	-	4		D		2	-				
4 I, 8 TSI, 23 BI, 12 BO						1	0	-	4		F		2	-				
4 I, 38 BI, 18 BO						1	0	-	7		A		6	-				
								-					-					
<i>Directional Overcurrent: I/O Configurations</i>						<u>6</u>	<u>Z</u>	-	<u>8</u>		<u>10</u>		<u>12</u>	-				
4 I, 4 V, 9 BI, 8 BO						1	1	-	1		A		1	-				
4 I, 4 V, 3 AFD, 9 BI, 11 BO (inc. 3 HSBO)						1	1	-	1		D		1	-				
4 I, 4 V, 8 TSI, 9 BI, 8 BO						1	1	-	1		F		1	-				
4 I, 4 V, 14 BI, 10 BO						1	1	-	2		A		2	-				
4 I, 4 V, 14 BI, 10 BO						1	1	-	2		A		6	-				
4 I, 4 V, 19 BI, 12 BO						1	1	-	3		A		2	-				
4 I, 4 V, 19 BI, 12 BO						1	1	-	3		A		6	-				
4 I, 4 V, 3 AFD, 19 BI, 15 BO (inc. 3 HSBO)						1	1	-	3		D		2	-				
4 I, 4 V, 3 AFD, 19 BI, 15 BO (inc. 3 HSBO)						1	1	-	3		D		6	-				
4 I, 4 V, 8 TSI, 19 BI, 12 BO						1	1	-	3		F		2	-				
4 I, 4 V, 24 BI, 14 BO						1	1	-	4		A		6	-				
4 I, 4 V, 3 AFD, 24 BI, 17 BO (inc. 3 HSBO)						1	1	-	4		D		6	-				
4 I, 4 V, 39 BI, 20 BO						1	1	-	7		A		6	-				
4 I, 4 V, 3 AFD, 39 BI, 23 BO (inc. 3 HSBO)						1	1	-	7		D		6	-				
4 I, 4 V, 8 TSI, 39 BI, 20 BO						1	1	-	7		F		6	-				
								-					-					
<i>Special Applications Overcurrent: I/O Configurations</i>						<u>6</u>	<u>Z</u>	-	<u>8</u>		<u>10</u>		<u>12</u>	-				
5 I, 4 V, 17 BI, 10 BO						2	1	-	2		A		2	-				
5 I, 4 V, 17 BI, 10 BO						2	1	-	2		A		6	-				
5 I, 4 V, 22 BI, 12 BO						2	1	-	3		A		6	-				
5 I, 4 V, 3 AFD, 22 BI, 15 BO (inc. 3 HSBO)						2	1	-	3		D		6	-				
5 I, 4 V, 37 BI, 18 BO						2	1	-	6		A		6	-				
5 I, 4 V, 3 AFD, 37 BI, 21 BO (inc. 3 HSBO)						2	1	-	6		D		6	-				
5 I, 4 V, 8 TSI, 37 BI, 18 BO						2	1	-	6		F		6	-				
													-					
<i>Auxiliary I/O (Slot 2)</i>											<u>10</u>			-				
No auxiliary I/O											A			-				
3 arc flash detector (AFD) inputs/3 BO (high speed)											D			-				
8 temperature sensor inputs (TSI)											F			-				
													-					
<i>CPU/Data Communication (Standard: 1 x USB (front), RS485 (rear) ports)</i>												<u>11</u>		-				
2 x RJ45 ports												1		-				
2 x optical LC ports												2		-				

4.4

Product Description	Order No.			
		-		
<u>Case & Fascia</u>	<u>12</u>	-		
Housing width 3/8 x 19" (size 6), Housing height 4U	1	-		
Housing width 1/2 x 19" (size 8), Housing height 4U	2	-		
Housing width 3/4 x 19" (size 12), Housing height 4U	6	-		
<u>Conformal Coating</u>			<u>13</u>	
Standard device (without conformal coating)			0	
Including conformal coating			1	



NOTE

CT inputs: 1 A/5 A, 50 Hz/60 Hz
 VT inputs: 40 V to 160 V, 50 Hz/60 Hz
 PSU: DC 24 V to DC 250 V, AC 100 V to AC 230 V
 PSU: AC = 50 Hz/60 Hz
 BI: DC 24 V/DC 110 V/DC 220 V
 IEC 61850 Ethernet editions 1 and 2
 Modbus TCP, DNP3 TCP
 Modbus RTU, IEC 60870-5-103, DNP3
 SNMP
 Syslog
 SNTP, IEEE 1588 PTP
 User selectable languages: English, French,
 German, Portuguese, Spanish, Turkish

Technical Documentation

Ordering Information

Ordering Information – 7SR54 Transformer Protection Relay

Product Description	Order No.																	
	1	2	3	4	5	6	7	8	9	10	11	12	13	14	15	16		
7SR54 Transformer Protection Relay	7	S	R	5	4	n	n	-	n	A	a	n	n	-	n	A	A	0
								-						-				
<u>2 Wdg. Transformer: I/O Configurations</u>						<u>6</u>	<u>Z</u>	-	<u>8</u>		<u>10</u>			-				
8 I, 16 BI, 8 BO						2	0	-	2		A		2	-				
8 I, 16 BI, 8 BO						2	0	-	2		A		6	-				
8 I, 21 BI, 10 BO						2	0	-	3		A		2	-				
8 I, 3 AFD, 21 BI, 13 BO (inc. 3 HSBO)						2	0	-	3		D		2	-				
8 I, 3 AFD, 21 BI, 13 BO (inc. 3 HSBO)						2	0	-	3		D		6	-				
8 I, 8 TSI, 21 BI, 10 BO						2	0	-	3		F		2	-				
8 I, 4 V, 12 BI, 8 BO						2	1	-	1		A		6	-				
8 I, 4 V, 17 BI, 10 BO						2	1	-	2		A		2	-				
8 I, 4 V, 3 AFD, 17 BI, 13 BO (inc. 3 HSBO)						2	1	-	2		D		2	-				
8 I, 4 V, 3 AFD, 17 BI, 13 BO (inc. 3 HSBO)						2	1	-	2		D		6	-				
8 I, 4 V, 8 TSI, 17 BI, 10 BO						2	1	-	2		F		2	-				
8 I, 4 V, 22 BI, 12 BO						2	1	-	3		A		6	-				
8 I, 4 V, 3 AFD, 22 BI, 15 BO (inc. 3 HSBO)						2	1	-	3		D		6	-				
8 I, 4 V, 8 TSI, 22 BI, 12 BO						2	1	-	3		F		6	-				
8 I, 4 V, 37 BI, 18 BO						2	1	-	6		A		6	-				
8 I, 4 V, 3 AFD, 37 BI, 21 BO (inc. 3 HSBO)						2	1	-	6		D		6	-				
8 I, 4 V, 8 TSI, 37 BI, 18 BO						2	1	-	6		F		6	-				
								-						-				
<u>3 Wdg. Transformer: I/O Configurations</u>						<u>6</u>	<u>Z</u>	-	<u>8</u>		<u>10</u>			-				
12 I, 24 BI, 10 BO						3	0	-	3		A		6	-				
12 I, 3 AFD, 24 BI, 13 BO (inc. 3 HSBO)						3	0	-	3		D		6	-				
12 I, 8 TSI, 24 BI, 10 BO						3	0	-	3		F		6	-				
12 I, 4 V, 25 BI, 12 BO						3	1	-	3		A		6	-				
12 I, 4 V, 3 AFD, 25 BI, 15 BO (inc. 3 HSBO)						3	1	-	3		D		6	-				
12 I, 4 V, 8 TSI, 25 BI, 12 BO						3	1	-	3		F		6	-				
12 I, 4 V, 35 BI, 16 BO						3	1	-	5		A		6	-				
12 I, 4 V, 3 AFD, 35 BI, 19 BO (inc. 3 HSBO)						3	1	-	5		D		6	-				
12 I, 4 V, 8 TSI, 35 BI, 16 BO						3	1	-	5		F		6	-				
														-				
<u>Auxiliary I/O (Slot 2)</u>											<u>10</u>			-				
No auxiliary I/O											A			-				
3 arc flash detector (AFD) inputs/3 BO (high speed)											D			-				
8 temperature sensor inputs (TSI)											F			-				
													-					
<u>CPU/Data Communication (Standard: 1 x USB (front), RS485 (rear) ports)</u>											<u>11</u>		-					
2 x RJ45 ports											1		-					
2 x optical LC ports											2		-					
												-						
<u>Case & Fascia</u>											<u>12</u>	-						
Housing width 1/2 x 19" (size 8), Housing height 4U											2	-						
Housing width 3/4 x 19" (size 12), Housing height 4U											6	-						
<u>Conformal Coating</u>											<u>13</u>							
Standard device (without conformal coating)											0							
Including conformal coating											1							

4.4



NOTE

CT inputs: 1 A/5 A, 50 Hz/60 Hz

VT inputs: 40 V to 160 V, 50 Hz/60 Hz

PSU: DC 24 V to DC 250 V, AC 100 V to AC 230 V

PSU: AC = 50 Hz/60 Hz

BI: DC 24 V/DC 110 V/DC 220 V

IEC 61850 Ethernet editions 1 and 2

Modbus TCP, DNP3 TCP

Modbus RTU, IEC 60870-5-103, DNP3

SNMP

Syslog

SNTP, IEEE 1588 PTP

User selectable languages: English, French,
German, Portuguese, Spanish, Turkish

Technical Documentation

Ordering Information

Ordering Information – 7SR57 Motor Protection Relay

Product Description	Order No.																	
	1	2	3	4	5	6	7	8	9	10	11	12	13	14	15	16		
7SR57 Motor Protection Relay	7	S	R	5	7	n	n	-	n	a	a	n	n	-	n	A	A	0
								-					-					
<u>Motor: I/O Configurations</u>						<u>6</u>	<u>Z</u>	-	<u>8</u>	<u>9</u>	<u>10</u>		<u>12</u>	-				
4 I, 8 BI, 6 BO						1	0	-	1	A	A		1	-				
4 I, 3 AFD, 8 BI, 9 BO (inc. 3 HSBO)						1	0	-	1	A	D		1	-				
4 I, 8 TSI, 8 BI, 6 BO						1	0	-	1	A	F		1	-				
4 I, 13 BI, 8 BO						1	0	-	2	A	A		1	-				
4 I, 3 AFD, 13 BI, 11 BO (inc. 3 HSBO)						1	0	-	2	A	D		1	-				
4 I, 8 TSI, 13 BI, 8 BO						1	0	-	2	A	F		1	-				
4 I, 18 BI, 10 BO						1	0	-	3	A	A		2	-				
4 I, 3 AFD, 18 BI, 13 BO (inc. 3 HSBO)						1	0	-	3	A	D		2	-				
4 I, 8 TSI, 18 BI, 10 BO						1	0	-	3	A	F		2	-				
4 I, 23 BI, 12 BO						1	0	-	4	A	A		2	-				
4 I, 3 AFD, 23 BI, 15 BO (inc. 3 HSBO)						1	0	-	4	A	D		2	-				
4 I, 8 TSI, 23 BI, 12 BO						1	0	-	4	A	F		2	-				
4 I, 4 V, 9 BI, 8 BO						1	1	-	1	A	A		1	-				
4 I, 4 V, 3 AFD, 9 BI, 11 BO (inc. 3 HSBO)						1	1	-	1	A	D		1	-				
4 I, 4 V, 8 TSI, 9 BI, 8 BO						1	1	-	1	A	F		1	-				
4 I, 4 V, 19 BI, 12 BO						1	1	-	3	A	A		2	-				
4 I, 4 V, 19 BI, 12 BO						1	1	-	3	A	A		6	-				
4 I, 4 V, 3 AFD, 19 BI, 15 BO (inc. 3 HSBO)						1	1	-	3	A	D		2	-				
4 I, 4 V, 3 AFD, 19 BI, 15 BO (inc. 3 HSBO)						1	1	-	3	A	D		6	-				
4 I, 4 V, 8 TSI, 19 BI, 12 BO						1	1	-	3	A	F		2	-				
4 I, 4 V, 3 AFD, 16 TSI, 29 BI, 19 BO (inc. 3 HSBO)						1	1	-	5	D	D		6	-				
								-					-					
<u>Motor Differential: I/O Configurations</u>						<u>6</u>	<u>Z</u>	-	<u>8</u>	<u>9</u>	<u>10</u>		<u>12</u>	-				
8 I, 4 V, 17 BI, 10 BO						2	1	-	2	A	A		2	-				
8 I, 4 V, 3 AFD, 17 BI, 13 BO (inc. 3 HSBO)						2	1	-	2	A	D		2	-				
8 I, 4 V, 8 TSI, 17 BI, 10 BO						2	1	-	2	A	F		2	-				
8 I, 4 V, 3 AFD, 16 TSI, 27 BI, 17 BO (inc. 3 HSBO)						2	1	-	4	D	D		6	-				
													-					
<u>Extended I/O Configurations</u>										<u>9</u>	<u>10</u>		<u>12</u>	-				
No extended I/O										A			-					
Standard I/O + 16 temperature sensor inputs (TSI)										D			6	-				
													-					
<u>Auxiliary I/O (Slot 2)</u>										<u>10</u>			-					
No auxiliary I/O										A			-					
3 arc flash detector (AFD) inputs / 3 BO (high speed)										D			-					
8 temperature sensor inputs (TSI)										F			-					
												-						
<u>CPU/Data Communication (Standard: 1 x USB (front), RS485 (rear) ports)</u>												<u>11</u>		-				
2 x RJ45 ports												1		-				
2 x optical LC ports												2		-				
													-					
<u>Case & Fascia</u>													<u>12</u>	-				
Housing width 3/8 x 19" (size 6), Housing height 4U													1	-				
Housing width 1/2 x 19" (size 8), Housing height 4U													2	-				
Housing width 3/4 x 19" (size 12), Housing height 4U													6	-				
<u>Conformal Coating</u>																<u>13</u>		

4.4

Product Description	Order No.			
Standard device (without conformal coating)		0		
Including conformal coating		1		



NOTE

CT inputs: 1 A/5 A, 50 Hz/60 Hz

VT inputs: 40 V to 160 V, 50 Hz/60 Hz

PSU: DC 24 V to DC 250 V, AC 100 V to AC 230 V

PSU: AC = 50 Hz/60 Hz

BI: DC 24 V/DC 110 V/DC 220 V

IEC 61850 Ethernet editions 1 and 2

Modbus TCP, DNP3 TCP

Modbus RTU, IEC 60870-5-103, DNP3

SNMP

Syslog

SNTP, IEEE 1588 PTP

User selectable languages: English, French,
German, Portuguese, Spanish, Turkish

Technical Documentation

Ordering Information

Ordering Information – 7SR5 Spares and Accessories

Product Description	Order No.																	
	1	2	3	4	5	6	7	8	9	10	11	12	13	14	15	16		
7SR5 Spares and Accessories	7	X	G	1	n	n	1	-	0	A	A	0	0	-	0	A	A	0
Fiber optic data communication port inserts (7SR5)					1	1												
Terminal plug for RS485 wiring (3-way)					1	3												
Terminal block cover (7SR5)					1	8												
Captive screws for fascia levers (7SR5)					6	1												
Hinged cover for fascia LED label (7SR5)					6	2												

Indication of conformity

This product is CE compliant to relevant EU directives.

Disclaimer of liability

This document has been subjected to rigorous technical review before being published. It is revised at regular intervals, and any modifications and amendments are included in the subsequent issues. The content of this document has been compiled for information purposes only. Although Siemens AG has made best efforts to keep the document as precise and up-to-date as possible, Siemens AG shall not assume any liability for defects and damage which result through use of the information contained herein. This content does not form part of a contract or of business relations; nor does it change these. All obligations of Siemens AG are stated in the relevant contractual agreements. Siemens AG reserves the right to revise this documentation time to time.

Document Edition: 7.0

Release Status: 04.2023

Version of the products described: V2.40

Copyright

Copyright © Siemens AG 2023. All rights reserved. The disclosure, duplication, distribution and editing of this document, or utilization and communication of the content are not permitted, unless authorized in writing. All rights, including rights created by patent grant or registration of a utility model or a design, are reserved.

Published by Siemens

Smart Infrastructure
Electrification & Automation
Mozartstr. 31 C
91052 Erlangen
Germany

Customer Support Center

Our Customer Support Center provides a 24-hour service.

Siemens AG
Smart Infrastructure - Protection Automation Customer Support Center

Phone: +49 911 2155 4466
Email: energy.automation@siemens.com

Article No: C53000-X7040-C022-1

Subject to changes and errors.

The information given in this document only contains general descriptions and / or performance features which may not always specifically reflect those described or which may undergo modification in the course of further development of the products.

The requested performance features are binding only when they are expressly agreed upon in the concluded contract.